



Your Solutions Partner

Specifications

F.O.B. Sedalia, Missouri 65301



TWHF-46PG
(shown with optional foodshield)

OPTIONS:

- 14 gauge tops
- Internal locking devices
- Recessed top to hold - 18" x 26" sheet pans, 1" deep
- Electric heat in base module
- Foodshields
- Workshelves
- Trayslides
- Food pans - See Top Equipment in Price Book
- Sliding/Hinged doors
- 8' or 10' cord and plug
- Veneered plastic laminate panels on body
- Powder coat paint colors
- 6" adjustable legs in lieu of casters
- Kickplates s/s or p/g

Agency Listings:



DUKE MANUFACTURING CO.
 2305 N. Broadway
 St. Louis, MO 63102
 800.735.3853 Toll Free
 314.231.5074 Fax
 www.dukemfg.com
 SS-1255 Ganged Waterless Well - Thurmduke

Specification subject to change



WARNING For CA residents: go to
www.dukemfg.com/prop65 for prop 65 warning

Approval Stamp(s):

PRODUCT INFORMATION:

PROJECT: _____

ITEM: _____

QUANTITY: _____

MODEL:

Thurmduke™ Serving Systems Ganged Waterless Well

- TWHF-32** 32" length unit, 2 top openings
- TWHF-46** 46" length unit, 3 top openings
- TWHF-60** 60" length unit, 4 top openings
- TWHF-74** 74" length unit, 5 top openings
- TWHF-88** 88" length unit, 6 top openings

TOP:

- 16 gauge, 300 Series stainless steel
- Die-stamped openings - 11-7/8" x 19-7/8"

Heat Compartments:

- 6-1/4" deep stainless steel liner for dry operation only
- 6' Cord and plug
- Includes Silicone bottom pad
- Fully Insulated
- Rope element in each compartment

CONTROLS:

- Standard intuitive, easy to use touch screen control - One control for all wells
- Easily adjusted presets LOW/MED/HIGH
- Built in WIFI and Bluetooth for future connectivity.

BODY:

- Choice of (12) powder coat paint colors**
- Stainless steel body**
 - Operator's side open to bottom shelf
 - Customer side and ends fully enclosed
 - Bottom shelf paint grip or stainless steel to match body
 - Recessed stainless steel dish shelf



Ganged Waterless Well

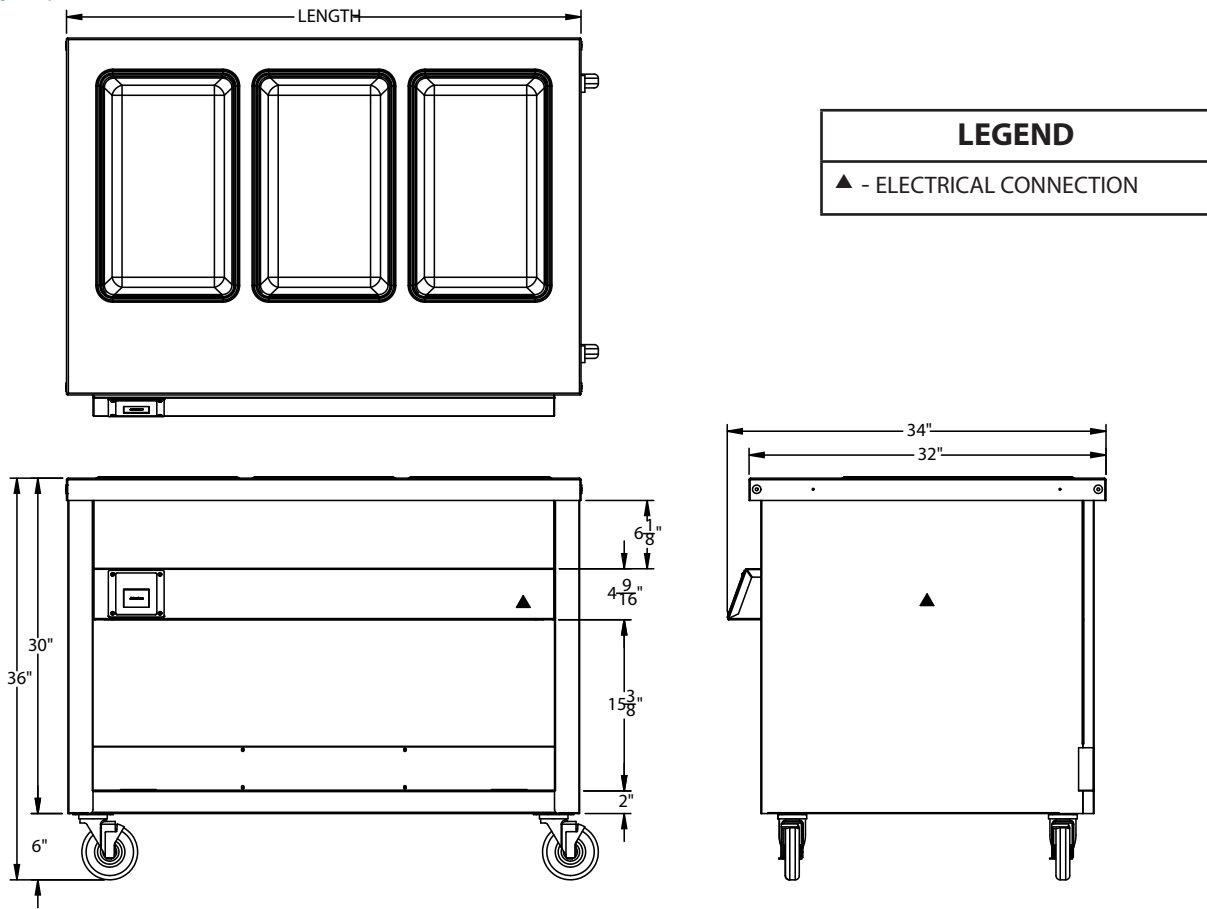

DIMENSIONS:

Freight Class: 150

Model	Length		Width		Height		Cube ft. crated	Weight		Top Openings
	in	cm	in	cm	in	cm		lbs	kg	
TWHF-32	32	81.3	32	81.3	36	91.4	34.8	253	115.0	2
TWHF-46	46	116.8	32	81.3	36	91.4	47.7	327	148.6	3
TWHF-60	60	152.4	32	81.3	36	91.4	60.5	400	181.8	4
TWHF-74	74	188.0	32	81.3	36	91.4	73.3	482	219.1	5
TWHF-88	88	223.5	32	81.3	36	91.4	86.2	595	270.5	6

ELECTRICAL SPECIFICATIONS:

Model	120 Volt - 665 watt elements			208 Volt - 500 watt elements			240 Volt - 665 watt elements		
	watts	amps	NEMA	watts	amps	NEMA	watts	amps	NEMA
TWHF-32	1330	11.1	5-15	1000	4.8	6-20	1330	5.5	6-20
TWHF-46	1995	16.6	L5-30	1500	7.2	6-20	1995	8.3	6-20
TWHF-60	2660	22.2	L5-30	2000	9.6	6-20	2660	11.1	6-20
TWHF-74	N/A	N/A	N/A	2500	12.1	6-20	3325	13.9	6-20
TWHF-88	N/A	N/A	N/A	3000	14.4	6-20	3990	16.6	6-20



Duke Manufacturing Co.
 2305 N. Broadway
 St. Louis, MO 63102

Phone: 314-231-1130
 Toll Free: 1-800-735-3853
 Fax: 314-231-5074

www.dukemfg.com