

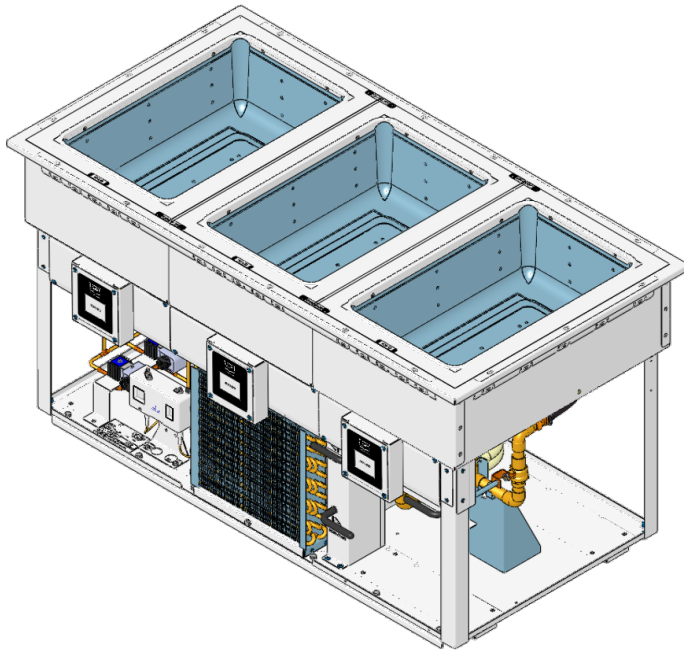

Specifications

F.O.B. Sedalia, Missouri 65301



Model HCF-3 Shown

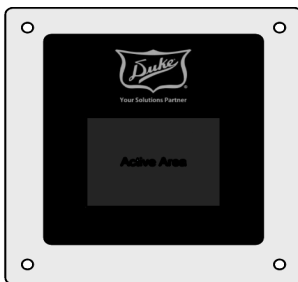

**Touch Screen Control
can be mounted in cabinet body**

OPTIONS:

- No drain, dry heat only with removeable non-stick liner

DUKE MANUFACTURING CO.
2305 N. Broadway
St. Louis, MO 63102
800.735.3853 Toll Free
314.231.5074 Fax
www.dukemfg.com
SS-1100 Duke HotColdFreeze

Approval Stamp(s):

PRODUCT INFORMATION:

PROJECT: _____

ITEM: _____

QUANTITY: _____

MODEL:

Duke HotColdFreeze™

- HCF-1 1 Wells
- HCF-2 2 Wells
- HCF-3 3 Wells
- HCF-4 4 Wells
- HCF-5 5 Wells

BODY:

- Top Mount with flush mount pans
- Stainless Steel - formed, welded, and polished to high finish
- Sealing gasket
- Drains at each well

CAPACITIES:

- Standard 12" x 20" steam table pans
- 2-1/2", 4" and 6" deep

CONTROLS:

- Intuitive, easy to use touch screen control changes mode of operation
- 3 wet heat, 3 dry heat, 3 refrigerated and 1 freeze mode.
- 1 control per food well
- Controls have a built-in Wifi modem and redundant controls capabilities for future activation.
- Six foot cord supplied between control and touchscreen
- Complies with part 15 of the FCC rules.

Refrigeration:

- 5 Year compressor replacement
- R448a Refrigerant
- Compressor slides out 15.375" for easy service.

Serviceability:

- Unit can be serviced in counter, no need to remove.
- Six foot Cord and plug supplied

CERTIFICATIONS:



ANSI/ NSF 169

Specification subject to change



REV H 10/19/2023

PRODUCT HOLDING UNIT - Duke HotColdFreeze™

Catalog No. Duke HotColdFreeze™

A.I.A. File No. 35-C-13

Duke HOTCOLDFREEZE™

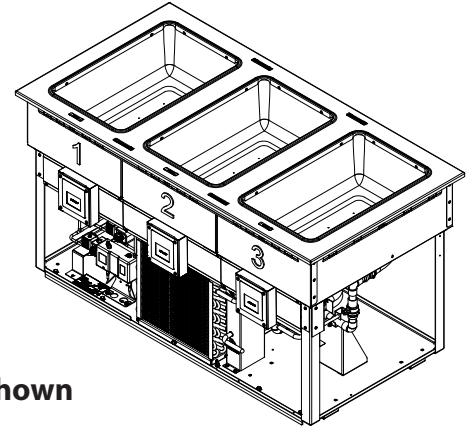
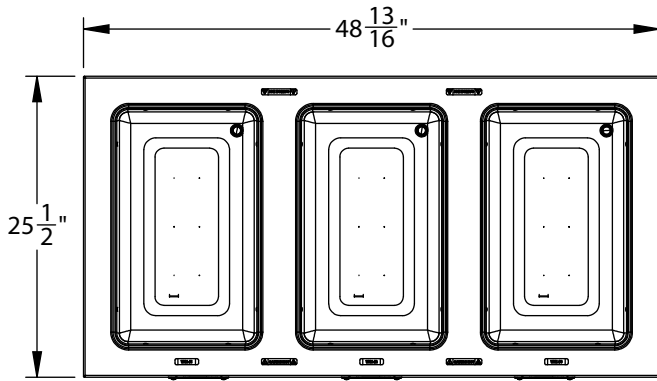

Model HCF-3 Shown

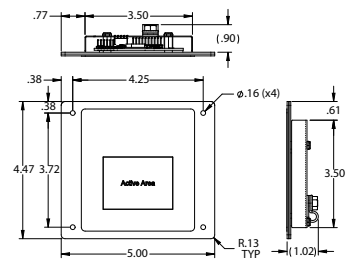
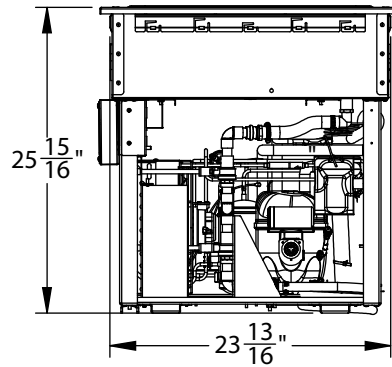
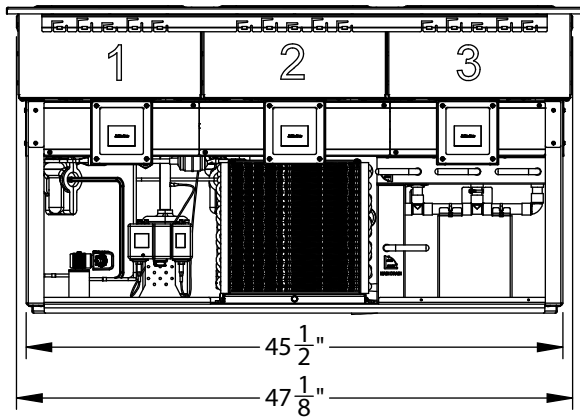

ELECTRICAL SPECIFICATIONS:

Model	120V/60Hz			120 / 208V 60Hz			120 / 240V 60Hz			Refrigeration				
	Watts	Amps	NEMA	Watts	Amps	NEMA	Watts	Amps	NEMA	HP	Refrig.	OZ	Grams	
HCF-1	660	5.5	5-15P	660	5.5	L14-20P	660	5.5	L14-20P		1/3	448a	15.0	466.6
HCF-2	1260	10.5	5-15P	1260	10.5	L14-20P	1260	10.5	L14-20P		1/3	448a	19.5	606.5
HCF-3	1920	16	5-20P	1320	11	L14-20P	1320	11	L14-20P		1/2	448a	30.0	933.1
HCF-4	2520	21	L5-30P	1920	16	L14-20P	1920	16	L14-20P		1/2	448a	38.0	1181.9
HCF-5	3360	28	5-50P	2064	17.2	L14-30P	2064	17.2	L14-30P	Sys-1	1/3	448a	19.5	606.5
HCF-5 +	4800	40	5-50P	2736	22.8	L14-30P	2736	22.8	L14-30P	Sys-2	1/2	448A	30.0	933.1
										Sys-1	1/3	448a	19.5	606.5
+ = Provided with one 120V, 15A general use convenience receptacle														

Note: Controls can be mounted in cabinet body

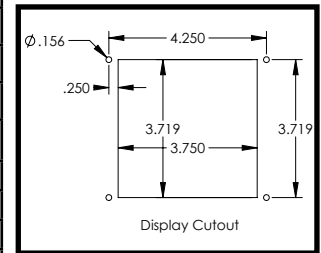

DIMENSIONS:

FREIGHT CLASS: 100

Model	Unit dimensions								Cutout Dimensions				Cube ft. Crated	Weight	
	Length		Depth		Height		Liner Widths		Length		Width			lbs	kg
	in	cm	in	cm	in	cm	in	cm	in	cm	in	cm			
HCF-1	17.50	44.45	25.5	64.77	25.94	65.89	23.82	60.50	16.00	40.64	24.00	60.96	12.5	95	43
HCF-2	33.19	79.22	25.5	64.77	25.94	65.89	23.82	60.50	31.69	80.50	24.00	60.96	21.0	145	65.8
HCF-3	48.82	124.00	25.5	64.77	25.94	65.89	23.82	60.50	47.38	120.35	24.00	60.96	28.9	198	89.8
HCF-4	64.50	163.82	25.5	64.77	25.94	65.89	23.82	60.50	63.00	160.02	24.00	60.96	38.0	287	130.2
HCF-5	80.19	203.68	25.5	64.77	25.94	65.89	23.82	60.50	79.00	200.66	24.00	60.96	45.0	340	154.2



Duke Manufacturing Co.
 2305 N. Broadway
 St. Louis, MO 63102

Phone: 314-231-1130
 Toll Free: 1-800-735-3853
 Fax: 314-231-5074

www.dukemfg.com Printed in U.S.A.
 © 2022, Duke Manufacturing Co.