

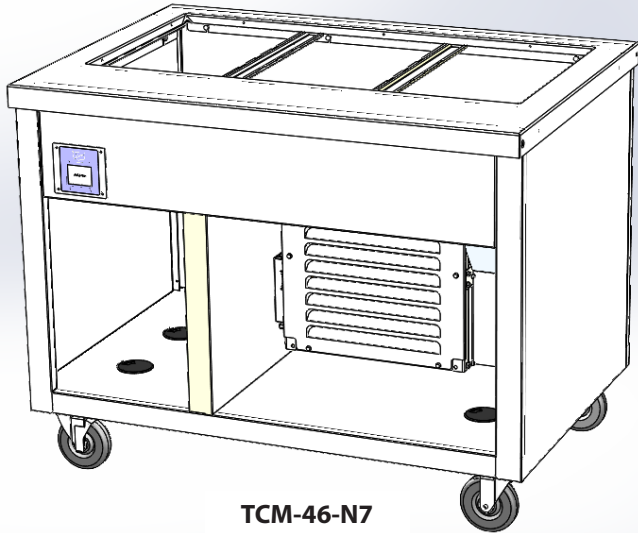

Your Solutions Partner

Specifications

F.O.B. Sedalia, Missouri 65301



TCM-46-N7

OPTIONS:

- Internal Locking device
- Basic Mechanical Control
- 14 gauge tops
- Condensate evaporator
- False Bottom
- Foodshields
- Work Shelves
- Trayslides
- Sliding doors
- 6" adjustable Stainless steel legs
- 8' or 10' cord and plug
- Food pans
- Veneered plastic laminate panels on body
- Powder coat paint colors
- Drain and condensing unit on operator's left
- Kickplates SS & PG
- 34" ADA height (units finish at 33.5"). Adjustable height casters with 5/8" adjustability allow leveling to 34".

AGENCY LISTINGS:



DUKE MANUFACTURING CO.
 2305 N. Broadway
 St. Louis, MO 63102
 800.735.3853 Toll Free
 314.231.5074 Fax
 www.dukemfg.com
 SS-1301 R290 Thurmaduke SS Cold Mech N7

Approval Stamp(s):

PRODUCT INFORMATION:

PROJECT: _____
 ITEM: _____
 QUANTITY: _____
 MODEL:

Thurmaduke™ Serving Systems - Cold Pan
Mechanically Cooled - Meets NSF Standard 7 - 8"
Deep

- **TCM-32-N7** 32" length unit
- **TCM-46-N7** 46" length unit
- **TCM-60-N7** 60" length unit
- **TCM-74-N7** 74" length unit
- **TCM-88-N7** 88" length unit

TOP:

- 16 gauge, 300 Series stainless steel
- Edges flanged down 2" at 90° - all four sides
- Inside edges flanged down 90° against liner

COLD PAN LINER:

- 300 Series stainless steel - 8" deep
- Insulated on all four sides and bottom
- 1" drain pipe and shut-off valve on operator's right

REFRIGERATION:

- Intuitive, ease to use touch screen control with 3 pre-set temperatures
- 120 VOLT - 1 Phase
- Refrigerant R290 
- Condensing unit below top on operator's right
- Stainless steel louvered grille for air circulation
- 6' electric cord and plug - NEMA 5-15
- Compressor enclosed in perforated aluminum

BODY:

- Choice of (12) powder coat paint colors contact sales
- Stainless steel body
- Operator's side open to bottom shelf
- Customer side and ends fully enclosed
- Bottom shelf paint grip or stainless steel to match body

Specification subject to change

 **WARNING** For CA residents: go to www.dukemfg.com/prop65 for prop 65 warning

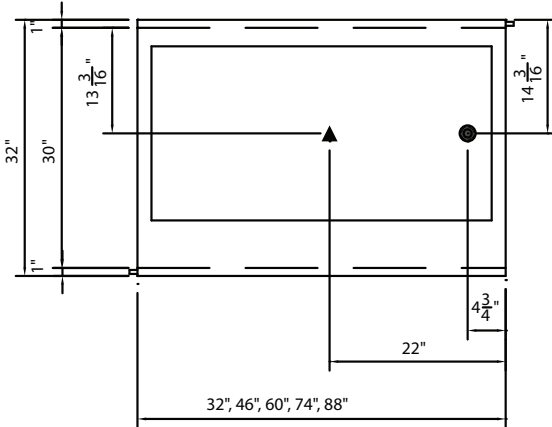

TOP VIEW

LEGEND	
▲	ELECTRICAL CONNECTION - 6' Cord & Plug
●	DRAIN LOCATION - 1" brass drain, shut-off valve, drain extension 7" above floor

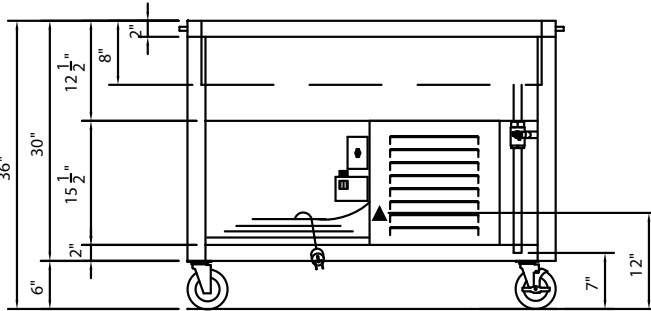

FRONT VIEW

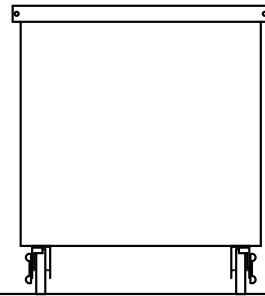

RIGHT SIDE VIEW

DIMENSIONS: Mechanical 8" Deep Cold Pan - All Units: Height - 36" (91.4 cm); Width - 32: (81.3cm)

FREIGHT CLASS: 150

Model	Body Length		Cold Pan Liner Dimensions						Cube ft. crated	Weight	
			Length		Width		Depth			lbs	kg
	in	cm	in	cm	in	cm	in	cm			
TCM-32-N7	32	81.3	28 ½	72.4	21 ¾	55.3	8	20.3	34.8	255	115.9
TCM-46-N7	46	116.8	42 ½	108.0	21 ¾	55.3	8	20.3	47.7	354	160.9
TCM-60-N7	60	152.4	56 ½	143.5	21 ¾	55.3	8	20.3	60.5	425	193.2
TCM-74-N7	74	188.0	70 ½	179.1	21 ¾	55.3	8	20.3	73.3	518	235.5
TCM-88-N7	88	223.5	84 ½	214.6	21 ¾	55.3	8	20.3	86.2	580	263.4

ELECTRICAL SPECIFICATIONS: (Consult factory for other options)

Model	120 Volt/NEMA 5-15	Refrig R290 ⚠
	Amps	Grams
TCM-32-N7	5.2	110
TCM-46-N7	5.2	110
TCM-60-N7	6.9	110
TCM-74-N7	6.9	110
TCM-88-N7	6.9	120



Duke Manufacturing Co.
2305 N. Broadway
St. Louis, MO 63102

Phone: 314-231-1130
Toll Free: 1-800-735-3853
Fax: 314-231-5074

www.dukemfg.com