

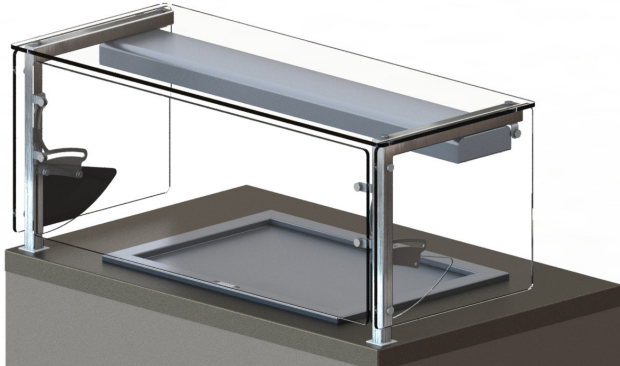

Your Solutions Partner

Specifications

F.O.B. Sedalia, Missouri 65301



Breath Guard Adj. Single Shelf, Single Sided,
Heat & Lights

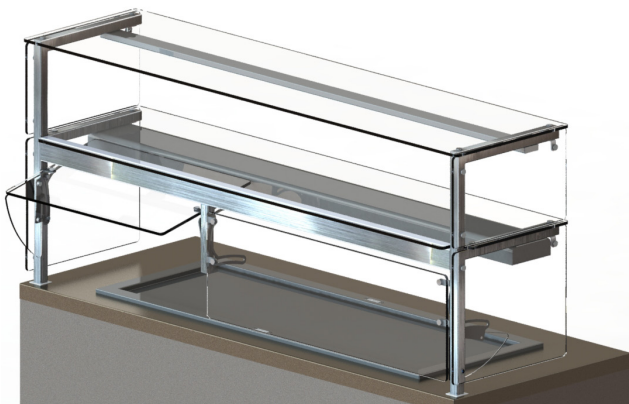

Breath Guard Adj. Dual Shelf ,Single Sided
Lower Heat & Light, Upper Light

OPTIONS:

- Mirror Finish
- Touch Screen Control
- Heater w/LED - Lower tier only
 - 120 Volt
 - 208 Volt
 - 240 Volt
- Special Length - Max 60" CL/CL per Section

DUKE MANUFACTURING CO.

2305 N. Broadway

St. Louis, MO 63102

800.735.3853 Toll Free

314.231.5074 Fax

www.dukemfg.com

SS-1271 BGA Series Food Guard

Approval Stamp(s):

PRODUCT INFORMATION:

PROJECT: _____

ITEM: _____

QUANTITY: _____

MODEL:

BGA Adjustable Food Guard Series

- BGA1-SS Single Shelf Single Sided
- BGA2-SS Dual Shelf Single Sided
- BGA1-DS Single Shelf Double Sided
- BGA2-DS Dual Shelf Double Sided

NOMINAL LENGTH (IN):

- 32
- 46
- 60
- 74
- 88

Controls:

- Basic Mechanical Control
- LED Lights standard

FRAMES:

- 1.25" Sq. Stainless Steel Tubing
- Grain Finish with Highlight Edge (Standard)

GUARDS:

- Through Mount mounting system
- Adjustable Front Glass
- 1/4" Tempered Wing Glass
- 3/8" Tempered Glass
- Clear polished edges on all glass
- 88" Maximum unsupported span

Certifications:



Specification subject to change

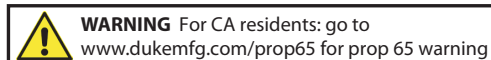

Rev E 02/26/2024

BGA1 Single Shelf Single Sided

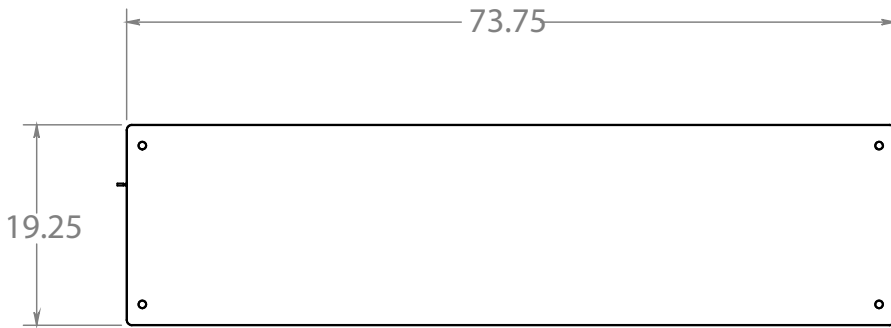
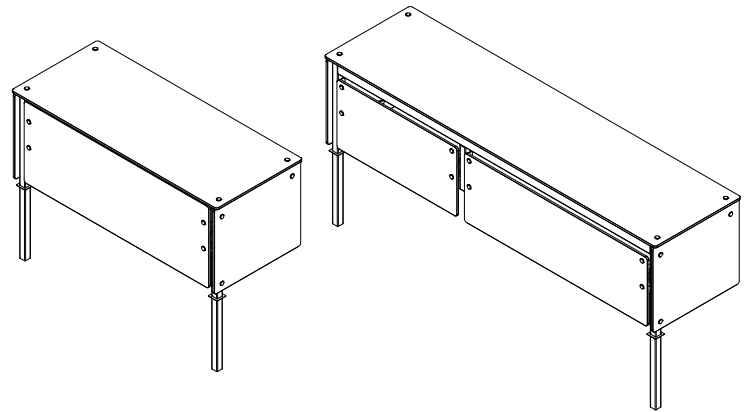

TOP VIEW

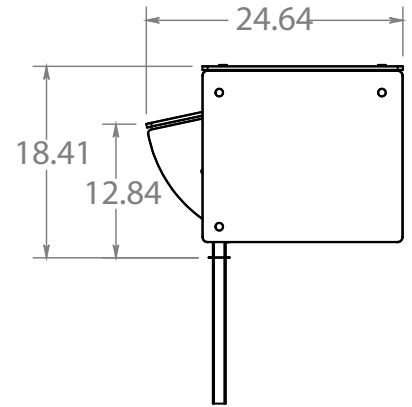

SIDE VIEW - GLASS OPEN

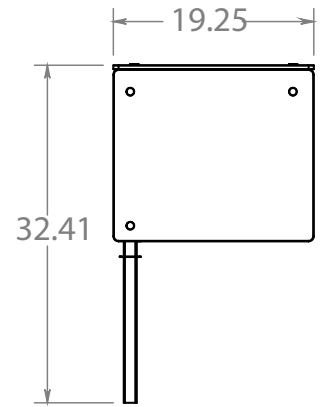
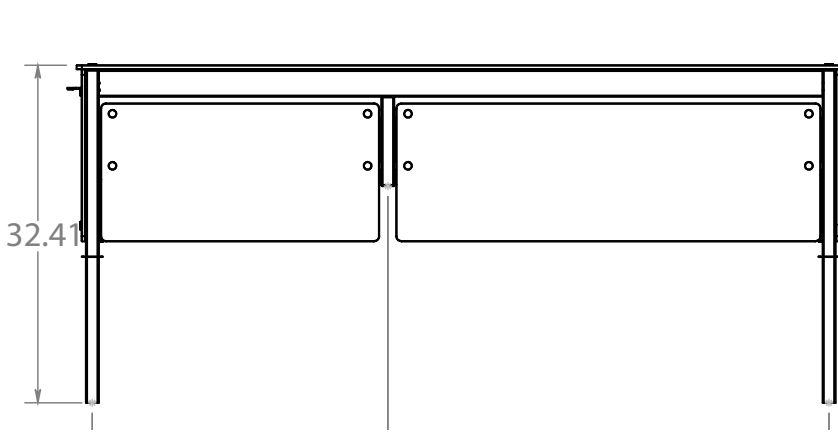

BGA1-74-SS Shown Above

Dimensions:

Freight Class: 100

Overall Height: 32.5 in./82.55 cm			Depth Overall: 19.25 in./48.90 cm						
Model	Length		Section 1 Length		Section 2 - Length		Cube ft. Crated	Crated Ship Weight	
	Overall		CL/CL		CL/CL			lbs.	kg
	in.	cm	in.	cm	in.	cm			
BGA1-32-SS	31.75	80.65	28.75	73.025	N/A		12	72	32.66
BGA1-46-SS	45.75	116.21	42.75	108.59	N/A		17	93	42.18
BGA1-60-SS	59.75	151.77	56.75	144.145	N/A		22	114	51.71
BGA1-74-SS	73.75	187.33	42.375	107.63	28.375	72.07	27	142	64.41
BGA1-88-SS	87.75	222.89	42.375	107.63	42.375	107.63	32	170	77.11

BGA1 = Single Shelf

SS-1271 BGA Series Food Guard

BGA2 Dual Shelf Single Sided

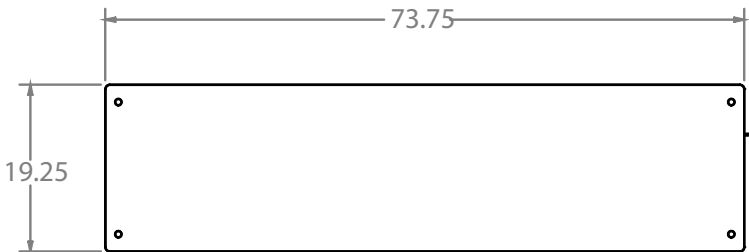
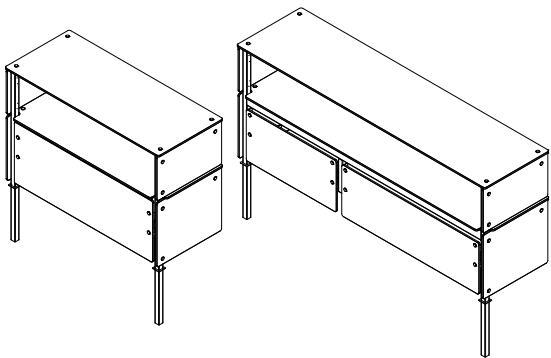

TOP VIEW

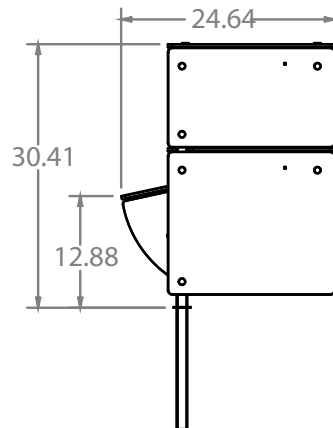

SIDE VIEW - GLASS OPEN

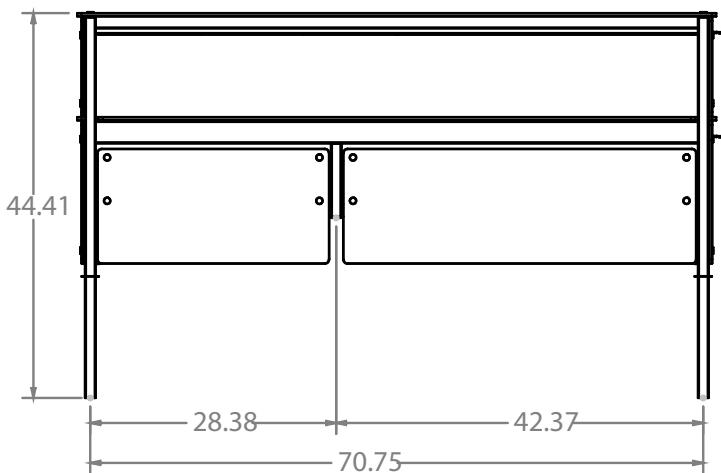

FRONT VIEW

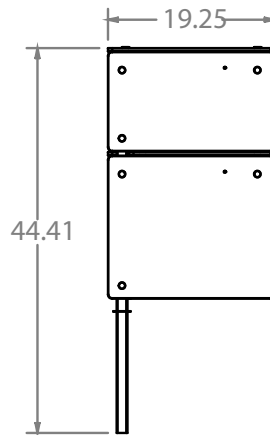

SIDE VIEW

BGA2-74-SS Dual Shelf Shown Above

Dimensions:

Freight Class: 100

Overall Height: 44.5 in./113.03 cm			Depth Overall: 19.25 in./48.90 cm						
Model	Length		Section 1 Length		Section 2 - Length		Cube ft. Crated	Crated Ship Weight	
	Overall		CL/CL		CL/CL			lbs.	kg
	in.	cm	in.	cm	in.	cm			
BGA2-32-SS	31.75	80.65	28.75	73.025	N/A		23	93	42.18
BGA2-46-SS	45.75	116.21	42.75	108.59	N/A		28	114	51.71
BGA2-60-SS	59.75	151.77	56.75	144.145	N/A		40	135	61.23
BGA2-74-SS	73.75	187.33	42.375	107.63	28.375	72.07	50	163	73.94
BGA2-88-SS	87.75	222.89	42.375	107.63	42.375	107.63	65	191	86.64

BGA2 = Dual Shelf

BGA1 Single Shelf Dual Sided

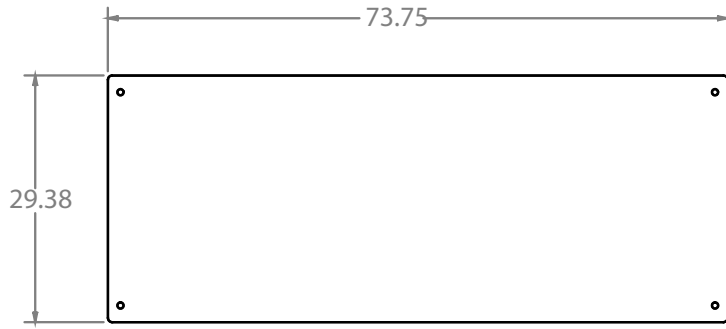
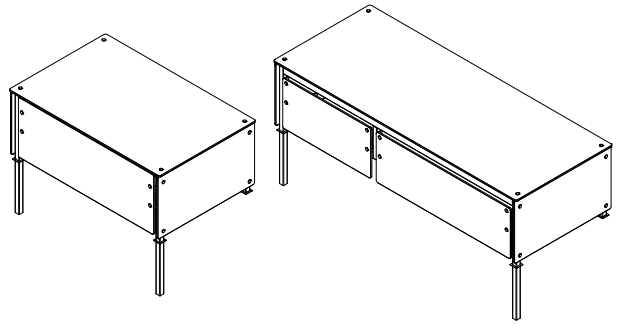

TOP VIEW

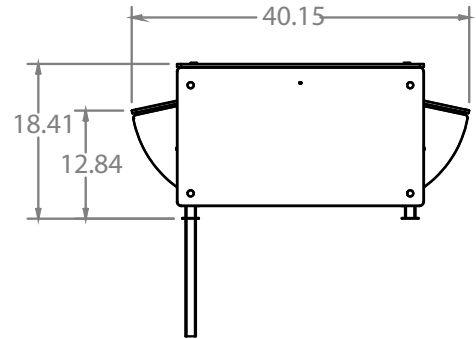

SIDE VIEW - GLASS OPEN

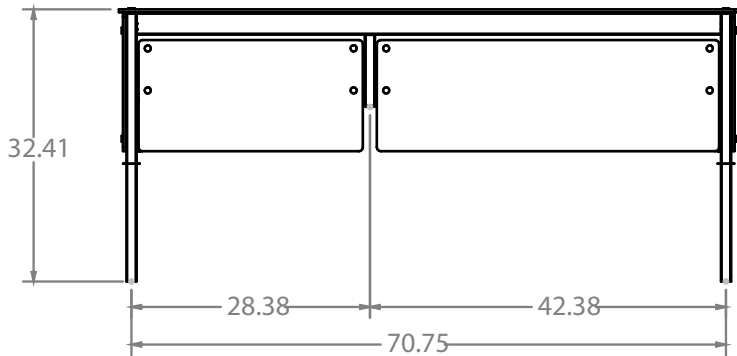

FRONT VIEW

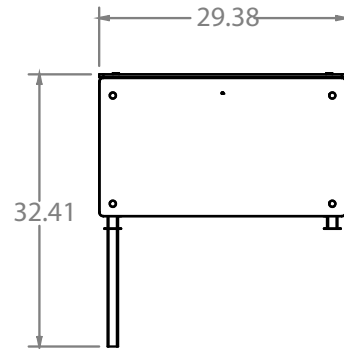

SIDE VIEW

BGA1-74-DS Shown Above

Dimensions:

Freight Class: 100

Overall Height: 32.5 in. / 82.55 cm				Depth Overall: 29.38 in. / 74.62 cm					
Model	Length		Section 1 Length		Section 2 - Length		Cube ft. Crated	Crated Ship Weight	
	Overall		CL/CL		CL/CL			lbs.	kg
	in.	cm	in.	cm	in.	cm			
BGA1-32-DS	31.75	80.65	28.75	73.025	N/A		36	86	39.01
BGA1-46-DS	45.75	116.21	42.75	108.59	N/A		42	107	48.53
BGA1-60-DS	59.75	151.77	56.75	144.145	N/A		62	128	58.06
BGA1-74-DS	73.75	187.33	42.375	107.63	28.375	72.07	90	156	70.76
BGA1-88-DS	87.75	222.89	42.375	107.63	42.375	107.63	108	184	83.46

**BGA1 = Single Shelf
DS - Dual Sided**

BGA2 Dual Shelf Dual Sided

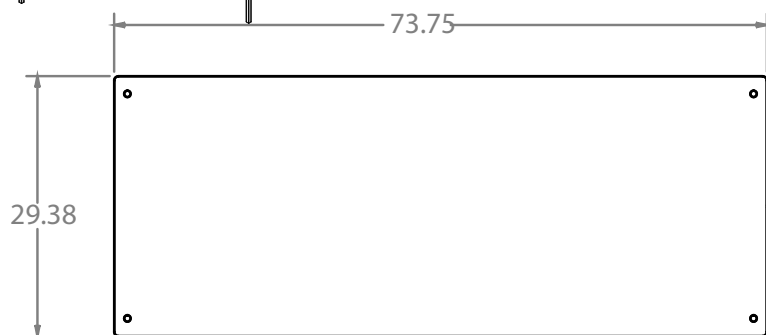
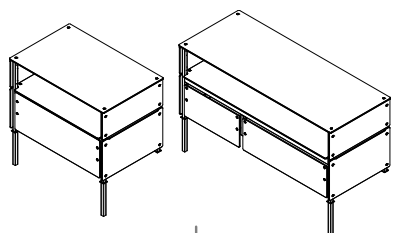

TOP VIEW

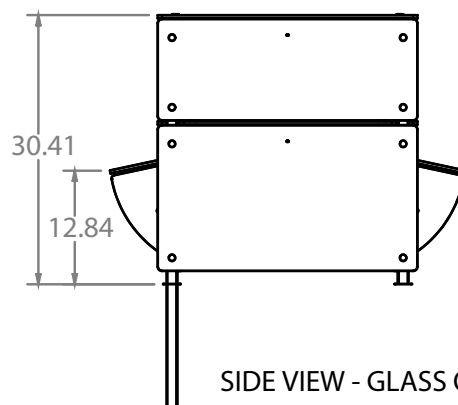

SIDE VIEW - GLASS OPEN

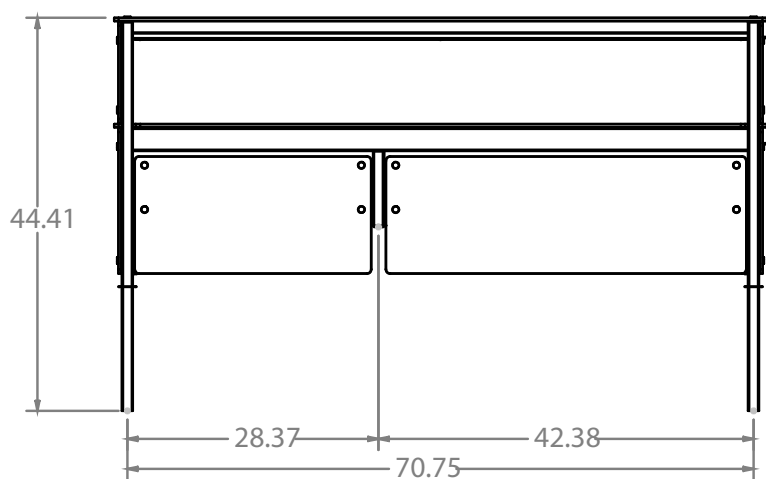

FRONT VIEW

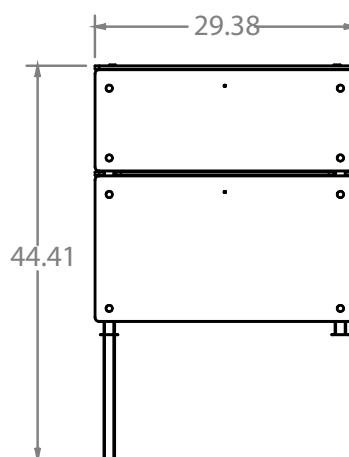

SIDE VIEW

BGA2-74-DS Shown Above

Dimensions:

Freight Class: 100

Overall Height: 44.5 in./113.03 cm		Depth Overall: 29.38 in./74.62 cm							
Model	Length		Section 1 Length		Section 2 - Length		Cube ft. Crated	Crated Ship Weight	
	Overall		CL/CL		CL/CL			lbs.	kg
	in.	cm	in.	cm	in.	cm			
BGA2-32-DS	31.75	80.65	28.75	73.025	N/A		25	107	48.53
BGA2-46-DS	45.75	116.21	42.75	108.59	N/A		35	128	58.06
BGA2-60-DS	59.75	151.77	56.75	144.145	N/A		46	149	67.59
BGA2-74-DS	73.75	187.33	42.375	107.63	28.375	72.07	56	177	80.29
BGA2-88-DS	87.75	222.89	42.375	107.63	42.375	107.63	67	205	92.99

BGA2 = Dual Shelf
DS = Dual Sided

BGA Food Guard Series

Electrical Specifications:

MODEL	120 Volt						120/208 Volt LED and Heater			120/240 Volt LED and Heater		
	LED Only NEMA 5-15P			LED and Heater			Watts	Amps	NEMA	Watts	Amps	NEMA
MODEL	Watts	Amps	Nema	Watts	Amps	NEMA	Watts	Amps	NEMA	Watts	Amps	NEMA
BGA1-32-SS	6	.05	5-15/P	357	3.0	5-15P	357	1.8	L14-20	357	1.6	L14-20
BGA1-46-SS	9.6	.08	5-15/P	586	4.9	5-15P	586	2.9	L14-20	586	2.5	L14-20
BGA1-60-SS	16.8	.14	5-15/P	941	7.9	5-15P	941	4.6	L14-20	941	4.1	L14-20
BGA1-74-SS	20.4	.17	5-15/P	1180	9.9	5-15P	1180	5.8	L14-20	1180	5.0	L14-20
BGA1-88-SS	24	.20	5-15/P	1296	10.8	5-15P	1296	6.3	L14-20	1296	5.5	L14-20
BGA2-32-SS	12	.10	5-15/P	364	3.1	5-15P	364	1.9	L14-20	364	1.7	L14-20
BGA2-46-SS	19.2	.16	5-15/P	596	5.0	5-15P	596	3.0	L14-20	596	2.6	L14-20
BGA2-60-SS	33.6	.28	5-15/P	957	8.0	5-15P	957	4.7	L14-20	957	4.2	L14-20
BGA2-74-SS	40.8	.34	5-15/P	1200	10.1	5-15P	1200	6.0	L14-20	1200	5.2	L14-20
BGA2-88-SS	48	.40	5-15/P	1317	11.0	5-15P	1317	6.5	L14-20	1317	5.8	L14-20
BGA1-32-DS	6	.05	5-15/P	357	3.0	5-15P	357	1.8	L14-20	357	1.6	L14-20
BGA1-46-DS	9.6	.08	5-15/P	586	4.9	5-15P	586	2.9	L14-20	586	2.5	L14-20
BGA1-60-DS	16.8	.14	5-15/P	941	7.9	5-15P	941	4.6	L14-20	941	4.1	L14-20
BGA1-74-DS	20.4	.17	5-15/P	1180	9.9	5-15P	1180	5.8	L14-20	1180	5.0	L14-20
BGA1-88-DS	24	.20	5-15/P	1296	10.8	5-15P	1296	6.3	L14-20	1296	5.5	L14-20
BGA2-32-DS	12	.10	5-15/P	364	3.1	5-15P	364	1.9	L14-20	364	1.7	L14-20
BGA2-46-DS	19.2	.16	5-15/P	596	5.0	5-15P	596	3.0	L14-20	596	2.6	L14-20
BGA2-60-DS	33.6	.28	5-15/P	957	8.0	5-15P	957	4.7	L14-20	957	4.2	L14-20
BGA2-74-DS	40.8	.34	5-15/P	1200	10.1	5-15P	1200	6.0	L14-20	1200	5.2	L14-20
BGA2-88-DS	48	.40	5-15/P	1317	11.0	5-15P	1317	6.5	L14-20	1317	5.8	L14-20

A.I.A. File No. 35-C-13

Catalog No. Through Mount

BGA1 = Single Shelf
BGA2 = Dual Shelf
SS - Single Sided
DS = Dual Sided

Control Specs

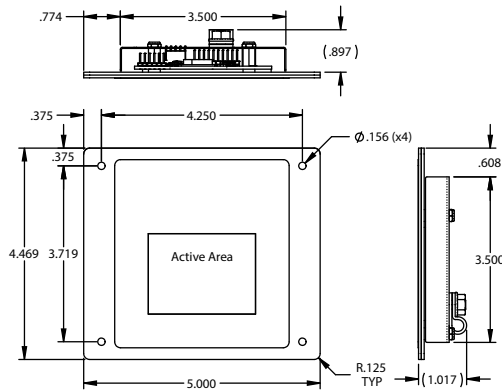

FOOD GUARD BGA SERIES 1 & 2



Duke Manufacturing Co.
 2305 N. Broadway
 St. Louis, MO 63102

Phone: 314-231-1130
 Toll Free: 1-800-735-3853
 Fax: 314-231-5074

www.dukemfg.com

SS-1271 BGA Series Food Guard

Printed in U.S.A.
 © 2023, Duke Manufacturing Co.