

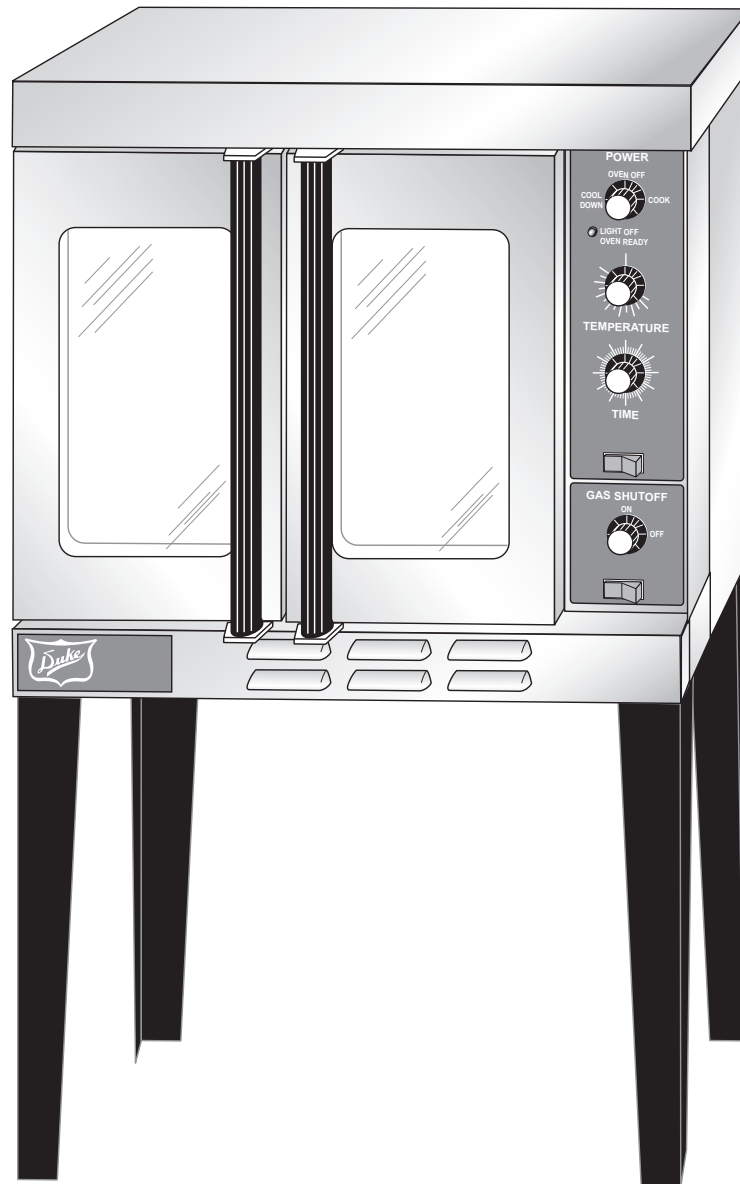

Your Solutions Partner

Installation and Operation Manual

613 & E SERIES GAS-FIRED CONVECTION OVEN



CAUTION: Please read this manual completely before attempting to install, operate or service this equipment

*This manual is Copyright © 2019 Duke Manufacturing Co. All rights reserved.
Reproduction without written permission is prohibited. Duke is a registered
trademark of the Duke Manufacturing Co.*

**P/N: 153810
REV AE 02/28/2019**

IMPORTANT WARNING AND SAFETY INFORMATION

POST IN A PROMINENT LOCATION instructions to be followed in the event the user smells gas. This information shall be obtained by consulting the local gas supplier.

FOR YOUR SAFETY:

Do not store or use gasoline or other flammable vapors or liquids in the vicinity of this or any other appliance.

⚠️ WARNING: Improper installation, adjustment, alteration, service or maintenance can cause property damage, injury or death. Read the installation, operating and maintenance instructions thoroughly before installing or servicing this equipment.

THIS MANUAL MUST BE RETAINED FOR FUTURE REFERENCE.

IMPORTANT SAFETY INSTRUCTIONS

Throughout this manual, you will find the following safety words and symbols that signify important safety issues with regards to operating or maintaining the equipment.



Indicates a hazardous situation which, if not avoided, could result in death or serious injury.



Indicates a hazardous situation which, if not avoided, could result in minor or moderate injury.



Indicates Important Information



Indicates electrical shock hazard which, if not avoided, could result in death or serious injury and/or equipment damage.



Indicates hot surface which, if not avoided, could result in minor or moderate injury.



Your Solutions Partner

In addition to the warnings and cautions in this manual, use the following guidelines for safe operation of the unit.

- Read all instructions before using equipment.
- For your safety, the equipment is furnished with a properly grounded cord connector. Do not attempt to remove or disconnect the grounded connector.
- Install or locate the equipment only for its intended use as described in this manual.
- Do not use corrosive chemicals on this equipment.
- Do not operate this equipment if it has a damaged cord or plug, if it is not working properly, or if it has been damaged or dropped.
- This equipment should be serviced by qualified personnel only. Contact the nearest Duke authorized service facility for adjustment or repair.
- Do not block or cover any openings on the unit.
- Do not immerse cord or plug in water.
- Keep cord away from heated surfaces.
- Do not allow cord to hang over edge of table or counter.

The following warnings and cautions appear throughout this manual and should be carefully observed.

- Turn the unit off, disconnect the power source and allow unit to cool down before performing any service or maintenance on the unit.
- The procedures in this manual may include the use of chemical products. You must read the Material Safety Data Sheets before using any of these products.
- The unit should be grounded according to local electrical codes to prevent the possibility of electrical shock. It requires a grounded receptacle with dedicated electrical lines, protected by fuses or circuit breaker of the proper rating, in accordance with all applicable regulations.
- Disposal of the unit must be in accordance with local environmental codes and/or any other applicable codes.
- This appliance is not intended for use by persons (including children) with reduced physical, sensory or mental capabilities, or lack of experience and knowledge, unless they have been given supervision or instruction concerning use of the appliance by a person responsible for their safety.





TABLE OF CONTENTS

IMPORTANT WARNING AND SAFETY INFORMATION 2-3

SPECIFICATIONS 5

INSTALLATION INSTRUCTIONS..... 6

 A. QUALIFIED PERSONNEL 6

 B. DELIVERY AND INSPECTION 6

 C. LOCATION OF THE OVEN 6

 D. GAS PIPING 7

 E. ELECTRICAL CONNECTIONS..... 7

 F. VENTILATION 7

 G. OVEN ASSEMBLY 8

 H. ADJUSTMENTS ASSOCIATED WITH INSTALLATION 9

 I. DOUBLE SECTIONS..... 9

OPERATING INSTRUCTIONS 10

 A. V-CONTROLLER..... 12

 B. XX CONTROLLER..... 13

GENERAL GUIDELINES FOR OPERATION..... 14

CLEANING OF THE OVENS 15

SUGGESTED COOK TIMES & TEMPERATURES..... 16

MAINTENANCE INSTRUCTIONS..... 17

 A. ADJUSTMENTS 17

 B. DOOR AJUSTMENT 17

 C. DOOR SWITCH ADJUSTMENT..... 17

 D. THERMOSTAT CALIBRATION 18

 E. GAS PRESSURE REGULATION AND ADJUSTMENT 18

 F. VENTILATION SYSTEM 19

ELECTRICAL SCHEMATIC..... 20



SPECIFICATIONS

	NATURAL GAS		PROPANE GAS	
HEATING VALUE	1000 BTU	37.3 MJ/m ³	2550 BTU	90.0 MJ/m ³
SPECIFIC GRAVITY	0.63	0.63	1.53	1.53
GAS PRESSURE AT MANIFOLD	3.5" W.C.	0.87 kPa	10" W.C.	2.49 kPa

OVEN INPUT – STANDARD DEPTH

	NATURAL GAS		PROPANE GAS	
PER BURNER	20,000 BTU/HR	5.9 kW	17,500 BTU/HR	5.1 kW
PER OVEN	40,000 BTU/HR	11.8 kW	35,000 BTU/HR	10.3 kW

OVEN INPUT – DEEP DEPTH

	NATURAL GAS		PROPANE GAS	
PER BURNER	23,000 BTU/HR	6.8 kW	23,000 BTU/HR	6.8 kW
PER OVEN	46,000 BTU/HR	13.5 kW	46,000 BTU/HR	13.5 kW

BURNER ORIFICE SIZE

	NATURAL GAS		PROPANE GAS	
STANDARD DEPTH	#44	2.18mm	(1) #55, (1) #57	(1)1.32mm, (1)1.09mm
DEEP DEPTH	#43	2.26mm	#54	1.40mm

INSTALLATION INSTRUCTIONS

A. QUALIFIED PERSONNEL

These installation instructions are for the use of qualified installation and service personnel only. Installation or service by other than qualified personnel may result in damage to the oven and/or injury to the operator.

Qualified installation personnel are those individuals, firms, companies or corporations which either in person or through an agent is engaged in and responsible for:

- The installation or replacement of gas piping or the connection, installation, repair or servicing of equipment, who are experienced in such work, familiar with all precautions required, and have complied with all requirements of state and local authorities having jurisdiction. See: National Fuel Gas Code NFPA 54 (ANSI Z223.1).
- The installation of electrical wiring from the electric meter, main control box or service outlet to the electrical appliance. Qualified installation personnel must be familiar with all precautions required and have complied with all requirements of state and local authorities having jurisdiction. See: National Electrical Code, ANSI/NFPA70.

The installation must conform with local codes, or in the absence of local codes, with the National Fuel Gas Code, ANSI Z223.1/NFPA 54, or the Natural Gas and Propane Installation Code, CSA B149.1 as applicable, including:

- The appliance and its individual shutoff valve must be disconnected from the gas supply piping system during any pressure testing of that system at test pressures in excess of 1/2 psi (3.5 kPa).
- The appliance must be isolated from the gas supply piping system by closing its individual manual shutoff valve during any pressure testing of the gas supply piping system at test pressures equal to or less than 1/2 psi (3.5 kPa).

For an oven equipped with casters, the installation shall be made with a connector that complies with the Standard for Connectors for Movable Gas Appliances, ANSI Z21.69/CSA 6.16 and a quick-disconnect device that complies with the Standard for Quick-Disconnect Devices for Use with Gas Fuel, ANSI Z21.4/CSA 6.9. When installing the oven with casters and quick-disconnect hose, adequate means must be provided to limit the movement of the oven without depending on the connector and the quick disconnect device or its associated piping to limit the oven movement. Restraining means may be attached to the vertical portion of the base frame in the rear of the oven.

B. DELIVERY AND INSPECTION

Duke Manufacturing Co. does everything within its power to insure you received your oven in good condition. They are strapped down on heavy wooden skids and surrounded by heavy "tri-wall" cartons to prevent shipping damage. They have all been carefully inspected before they were packaged and consigned to the carrier.

Upon delivery of your Duke oven:

- Look over the shipping container, carefully noting any exterior damage on the delivery receipt, which must also be signed by the driver/ delivery person.
- Uncrate and check for any damage, which was not evident on the outside of the shipping container. This is called concealed damage. The carrier must be notified within fifteen (15) days of the delivery of the oven and the carton, skid and all packaging materials must be retained for inspection.

Duke Manufacturing Co. cannot assume liability for loss or damage suffered in transit. The carrier assumes full responsibility for delivery in good order when the shipment was accepted. However, we are prepared to assist you in filing your claim.

C. LOCATION OF THE OVEN

Proper planning and placement of the oven will give you the best results in terms of long-term user convenience and satisfactory performance. We urge you to give adequate thought in the placement of your oven prior to its arrival.

- The oven should be placed in an area that is free from drafts and accessible for proper operation and servicing.
- The area around the oven must be kept clear of combustible materials. A minimum clearance must be maintained between the oven and any combustible or non-combustible surface.

MINIMUM CLEARANCES

	Combustible	Non-Combustible
RIGHT SIDE	1"	0"
LEFT SIDE	1"	0"
REAR	3"	3"
FLOOR	8"	8"



INSTALLATION INSTRUCTIONS - Continued

D. GAS PIPING

Each section of the "E" Series or 6/13-G Ovens (standard depth) is rated at 40,000 BTU's per hour (11.7 kW) or (deep depth) 46,000 BTU's per hour (13.5 kW). Therefore, 38-40 (standard), 44-46 (deep) cubic feet of natural gas or 16 (standard), 18.4 (deep) cubic feet of propane gas per hour must be supplied to each unit (stacked units count as two) when the oven is full on. In order to achieve the degree of performance for which the unit has been designed, the overall piping plan of the kitchen, properly sized, is essential. The installation of this oven must conform with all local codes, or in the absence of any local codes, to the National Fuel Gas Code, NFPA 54 and ANSI Z 223.1.

Your local gas supplier should consult the National Fuel Gas Code for proper sizing and installation of gas piping. Generally, piping should be sized to provide a gas supply sufficient to meet the maximum demand of all gas appliances on a line without undue loss of pressure at the outlet to the equipment. The total BTU requirements of the equipment being served and the length of the piping from the meter to the appliances are major considerations in the proper design of the gas supply system.

This oven has been tested and certified for use on gas systems that do not exceed 1/2 psi (3.45 kPa) of pressure. If the piping system is tested at a pressure higher than 1/2 psi (3.45 kPa), this oven should be isolated from the supply by disconnecting it. If the piping system is tested at a pressure lower than or equal to 1/2 psi (3.45 kPa), this oven should be isolated from the supply by shutting off the manual shut off valve located on the front panel.

From National Fuel Gas Code:

MAXIMUM CAPACITY OF IRON PIPE IN CUBIC FEET PER HOUR (PRESSURE DROP OF 0.5" W.C.) NATURAL GAS

Length in Feet	1/2"	3/4"	1"	1-1/2"	2"
10	175	360	680	2100	3950
20	120	250	465	1460	2750
30	97	200	375	1180	2200
40	82	170	320	990	1900
50	73	151	285	900	1680
60	66	138	260	810	1520
70	61	125	240	750	1400
80	57	118	220	690	1300
90	53	110	205	650	1220
100	50	103	195	620	1150

MAXIMUM CAPACITY OF PIPE IN THOUSANDS OF BTU'S PER HOUR OF UNDILUTED PROPANE GAS AT 11" W.C.

Length in Feet	1/2"	3/4"	1"
10	275	567	1071
20	189	393	732
30	152	315	590
40	129	267	504
50	112	237	448
60	103	217	409
70	96	196	378
80	86	185	346
90	83	173	322
100	78	162	307

E. ELECTRICAL CONNECTIONS

Your oven is supplied for connection to a 115 volt, single phase grounded circuit. The electric motor, oven lights, indicator lights and control circuits are connected through a seven-foot electric supply cord found at the rear of the oven.

Before making any connections to these units, check the rating plate to assure that the voltage and phase of the oven is compatible with the electrical supply. When installing, all ovens must be electrically grounded in accordance with local codes, or in the absence of local codes, with the National Electrical Code, ANSI/NFPA 70 (in Canada - CSA Std. C22.2). Wiring diagrams are located in the control compartment area of the oven. Standard wiring schematics are also provided with this manual.

⚠ WARNING: This appliance is equipped with a three-prong (grounding) plug for your protection against shock hazard and should be plugged directly into a properly grounded three-prong receptacle. DO NOT cut or otherwise remove the grounding prong from this plug.

F. VENTILATION

Proper ventilation is very important for the proper function of your oven. A good ventilation system will allow the oven to function properly as well as remove unwanted vapors and products of combustion. Not venting the ovens properly can result in unsatisfactory baking results as well as the possibility of damaging your oven. To keep your warranty in force, a proper ventilation system must be employed, either direct vented or under a canopy.



INSTALLATION INSTRUCTIONS - Continued

Venting to a Canopy Exhaust Hood

The best way to vent your oven is by placing it under a properly designed mechanically driven exhaust hood. The hood should be sized so the equipment that it is designed to ventilate fits underneath with a minimum six (6) inch (152 mm) overhang on all sides not adjacent to a wall. The distance from the floor to the lower edge of the canopy should not exceed seven (7) feet (2.2 m).

The hood should have adequate capacity and provide a sufficient supply of make-up air. Ventilation hoods come in many sizes and capacities. Hood capacity is expressed in cubic feet per minute (CFM). The total make-up and exhaust air required for the canopy hood should be about 22 CFM per oven section. Information for the proper construction and installation of ventilating hoods may be obtained from the "Standard for the Installation of Equipment for the Removal of Smoke and Grease-Laden Vapors from Commercial Cooking Equipment, NFPA-96".

Direct Flue Venting

Occasionally it is not possible or practical to install a powered canopy hood. In those cases the oven can be vented directly by means of a direct flue method. Correctly venting your oven is very important to insure proper cooking results and preclude any premature failures in the burner or burner compartment. The direct flue method incorporates a draft hood that is mounted to the top of the oven (or the upper oven section in a stacked unit). The flue then rises from the draft hood vertically to a point 6-8 feet above the roof or any close structure. The flue is then capped with an approved vent cap to isolate the flue from the external environmental conditions.

The direct flue method does not incorporate the ability to replace air consumed by and vented from the oven. An adequate supply of room make-up air must be provided if your oven is to be vented by this method. The total makeup air requirement for one oven section is approximately 30 CFM.

Lighting Instructions:

- Turn Gas Shut Off to ON Position
- Turn Power Switch to COOK Position
- Set Thermostat to Desired Temperature

Shut Down Instructions:

- Turn Power Switch to OFF Position
- Wait 5 Minutes Before Relighting Oven

⚠ WARNING: Keep the oven area free and clear from combustibles.

NOTE: This manual must be retained for future reference.

G. OVEN ASSEMBLY

Before assembling and installing the oven, please check to make sure that all necessary parts are present. In addition to the oven itself, there will also be legs, feet or casters, the flue/vent guard or draft hood and draft hood collar assembly, (for double sections, retaining clips, flue riser and/or common manifold) and miscellaneous hardware. Please check the interior of all oven sections for the parts needed to assemble and install your oven(s).

Leg Attachment

- Once the oven has been removed from the carton, lay it on its left side (the side without the controls), hold the leg and align with the threaded holes in the front corner of the bottom of the oven. Carefully start the threads of the corner leg bolt (5/16"-18 X 1/2"), avoid cross threading.
- Align the leg plate holes in each leg with those in the corners of the oven bottom and secure using two 5/16"-18 x 1/2" bolts. Tighten all bolts firmly. Repeat this procedure for all legs.
- Raise the oven up on its legs. Level the oven by turning the adjustable feet in or out as needed.

Caster Installation

- Casters are available as an option for both the single and double oven sections.
- The installation of casters requires the removal of the adjustable feet from the legs. This is done by placing the bit of a large screwdriver against the lip of the foot and rapping the screwdriver to drive the foot out of the leg. The caster is then inserted fully into the opening where the foot came out and the locking nut tightened to expand the compression sleeve of the caster.

NOTE: The casters with locking brakes are best mounted on the front side of the oven for easier access.

NOTE: If you plan to use casters and flexible fuel gas connectors, a fixed restraint of the proper length must be incorporated to secure the oven to a non-movable surface to eliminate strain on the connector. If the oven is removed from its normal position, the restraint must then be reattached when returned.



Your Solutions Partner

INSTALLATION INSTRUCTIONS - Continued

Installation of the Vent

- Ovens ordered for installation under a powered canopy exhaust hood should have the flue guard in place. This item can be installed by placing it over the flue opening, making sure that it does not obstruct the flue, and attaching it with the screws provided.
- Ovens ordered for installation in a location other than under a powered canopy exhaust hood are supplied with a draft hood & draft hood collar. This device mounts to the top of the upper oven section by attaching the draft hood adapter to the flue opening with the screws provided, the draft hood is then mounted on top of the adapter. The flue pipe is attached vertically to the draft hood.

H. ADJUSTMENTS ASSOCIATED WITH INSTALLATION

Each oven section and all its component parts have been tested thoroughly and inspected before your oven was shipped from the factory. However, it is sometimes necessary to further test or adjust the oven once it has been installed. Such adjustments are the responsibility of the Dealer or Installer. These types of adjustments are not considered defects, rather a normal and routine part of the proper installation of the equipment. These adjustments include but are not limited to:

- Adjustments and recalibration of the thermostat
- Adjustment to the doors
- Burner or pilot adjustment.
- Adjustments to the gas pressure regulator.
- Leveling, and tightening of fasteners.

No installation should be considered complete without proper inspection and, if necessary, any adjustments by qualified service or installation personnel.

It is also important not to obstruct the natural flow of combustion and ventilation air if the oven is to operate properly. This oven should not be installed on a curb base or sealed to the wall. Either condition can restrict the flow of air to the combustion compartment or prevent proper ventilation of the blower motor. The blower motor has a thermal protection device that will trip because of excessive ambient temperature at the back of the oven. This condition should be corrected immediately to avoid damaging the oven permanently.

Before making any connections to the oven, check the ratings plate to be sure the oven specifications concur with the type of gas and voltage to be supplied to the oven.

The rating plate is located behind the lowered lower front panel. To access, loosen the four screws below the doors, and pull panel outward.

The plate bearing the oven's serial number is attached to the underside of the upper ledge above the control panel.

I. DOUBLE SECTIONS

- Secure the short legs to the bottom of the lower section as described in previous section.
- Casters are installed by the method described for single section ovens. Previous section.
- Place upper section on top of lower section and align all edges of the ovens.
- Locate securing clips and align with holes on rear frames of oven section, install three screws each as provided and tighten.
- At the rear of the oven, install the flue connector by sliding it up through the flue vent opening in the top of the oven and over the upper flue vent. Push it flush with the back of the oven then slide it down over the lower flue vent. Attach with screws provided.
- Install flue guard or draft hood adapter, draft hood and draft hood collar to upper section.



INSTALLATION INSTRUCTIONS - Continued

Mounting Flue Extension to Top Oven

1. Remove existing flue trim from the top of oven.
2. Insert flue extension thru top opening first and then align holes on flue extension with holes on rear panel of oven.
3. Use 6 of the 8 screws (10-24x1/2") hex washer head that are provided to attach the flue extension to the rear panel of the oven as shown in figure. The other 2 screws are extras and are not used.
4. Re-install the existing flue trim.

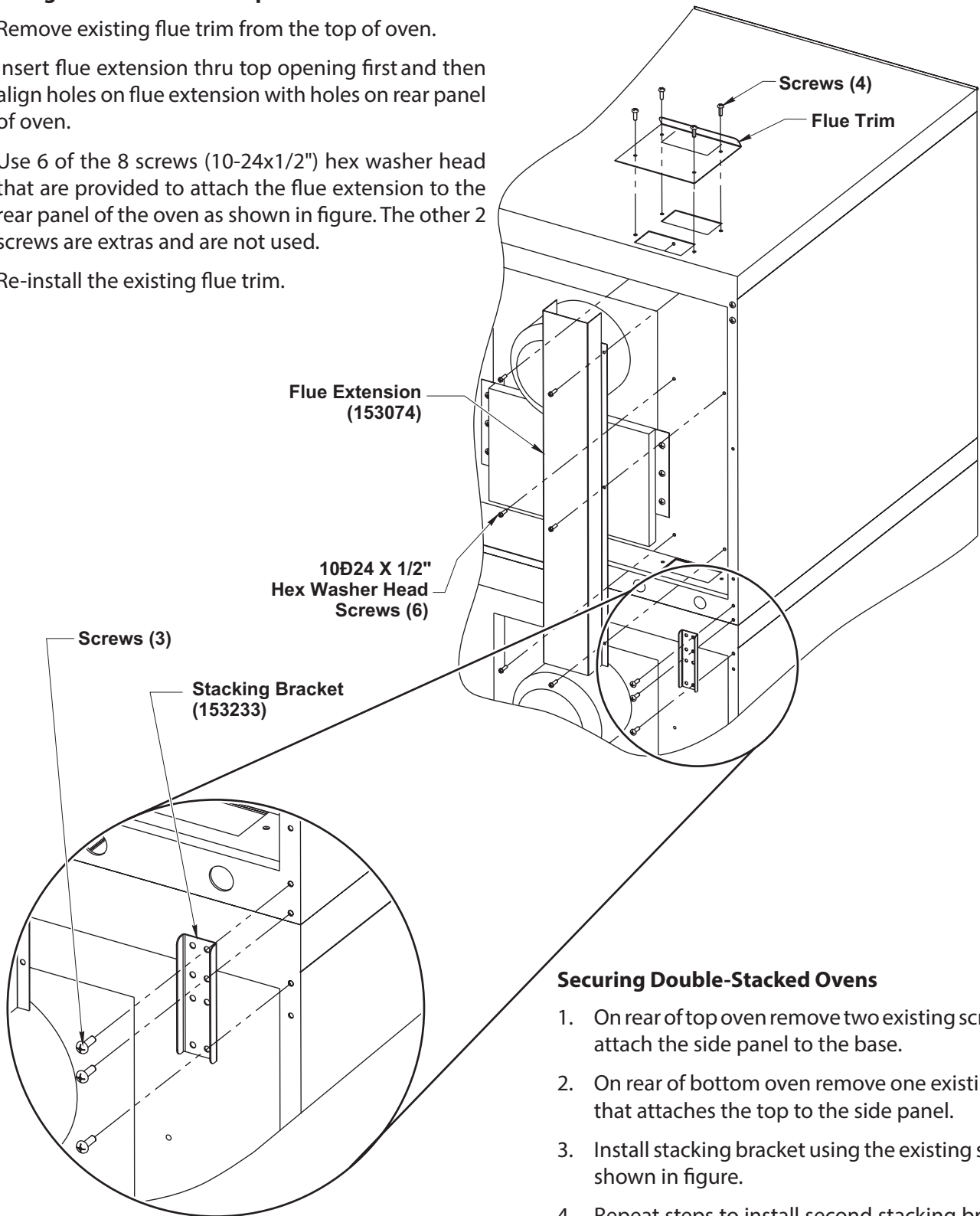

Securing Double-Stacked Ovens

1. On rear of top oven remove two existing screws that attach the side panel to the base.
2. On rear of bottom oven remove one existing screw that attaches the top to the side panel.
3. Install stacking bracket using the existing screws as shown in figure.
4. Repeat steps to install second stacking bracket on other side.

OPERATING INSTRUCTIONS

The information in this section is intended for the use of qualified operating personnel. Qualified Operating Personnel are those individuals who have carefully read the information contained in this manual, are familiar with the function of the oven and/or have had experience with operating the equipment described. We recommend following these instructions to insure optimum performance, long life and trouble-free service from your oven.

THE "E" AND 6/13 SERIES OF CONVECTION OVENS

Convection cooking has been around from the 1960s. Its advantages are well known. It differs from conventional cooking by the movement of heated air within the cooking cavity by means of a fan. This moving, heated air helps to strip the cool air from around the product being cooked, allowing the heat to penetrate more rapidly. The results are that your product is cooked quicker and at a lower temperature with the comparable product quality found in conventional ovens.

The "E" and 6/13 Series of ovens represent the very latest in energy efficiency technology with an appreciable reduction in NOx emissions over other gas fired ovens, both convection and conventional. The introduction of heat directly to the cooking cavity precludes any undue thermal loss due to the venting away of heated air before it has utilized its energy to cook product. This results in lower flue temperatures and hence, less heat loss to your kitchen so your exhaust and air conditioning systems do not work as hard. Also, the "over-sized" cooking cavity allows you to cook more products in each load.

All of this in addition to superior cooking results means the "E" and 6/13 Series of gas fired convection ovens are outstanding values. In addition, lower NOx emissions means it's environmentally friendly. Please take the time to carefully read the operating instructions. They are important in the successful use of your oven.

⚠ WARNING: The "E" and 6/13 Series Convection Ovens rely on electricity for powering the ignition system and the fan. Do not attempt to operate during a power failure.



OPERATING INSTRUCTIONS - continued

V-CONTROLLER

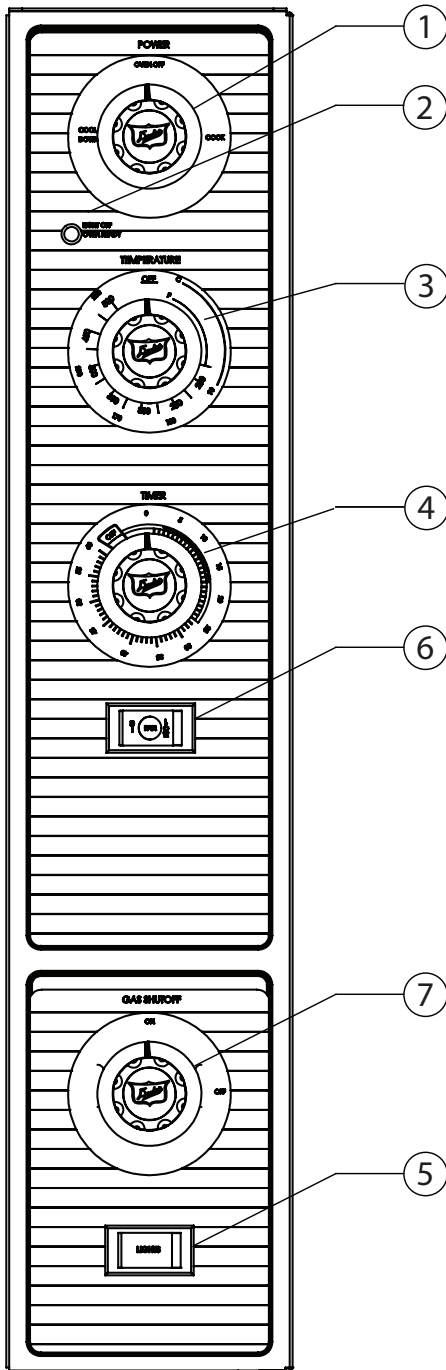

A. Oven Controls

Electro-Mechanical

1. Power Switch - Controls power to ON or Cool Down Function.
2. Indicator Light - When lit indicates burners are operating. When the light goes out, the oven has reached its cooking temperature.
3. Cooking Thermostat - Controls the oven temperature.
4. Cooking Timer - Sounds an electric buzzer on expiration of operator set time as a reminder to remove product at end of cooking cycle.

NOTE: To set times of less than 25 minutes, turn timer knob past 25 minutes and then back to the desired time.

5. Light Switch (Optional) - Controls interior lights.
6. Fan Speed Switch (Optional) - Sets fan speed to high or low.
7. Manual Gas Shut Off Valve - Turns gas supply to oven controls on or off.

Operating Instructions – V Controller

Timer Resolution

The Timer displays time from 0 to 60 minutes, in one-minute increments.

Temperature Scale

The Temperature Control displays the temperature in °F. The temperature range is from 150°F - 500°F, in 25°F increments.

Cool Down

This feature enables the oven to be cooled rapidly by allowing the fan to operate with the burners turned off. To activate, turn the Power Switch to the COOL position and open the oven door. When the door is opened enough to disengage the door switch, the fan will turn on. Closing the door will turn the fan off.

Fan Speed Switch

The fan speed can be set to high or low speed by placing the FAN HI/LOW button to the desired setting.

Cooking

A cooking cycle can be initiated as follows:

- Turn the Power Switch to COOK position.
- Set the Cooking Temperature by turning the TEMPERATURE dial to the desired temperature. The OVEN READY indicator light will turn on.
- When the OVEN READY indicator light turns off, place the product to be cooked in the oven.
- Set the cooking Time by turning the COOK TIMER dial to the desired time.

NOTE: To set times of less than 25 minutes, turn timer knob past 25 minutes and then back to the desired time.

During the Cook Cycle, The OVEN READY Indicator light will cycle on and off with the heating elements.

- When the COOK TIMER reaches “zero”, the alarm will sound.
- To cancel the alarm, turn the COOK TIMER dial to the OFF position.



Your Solutions Partner

OPERATING INSTRUCTIONS - continued

XX CONTROLLER

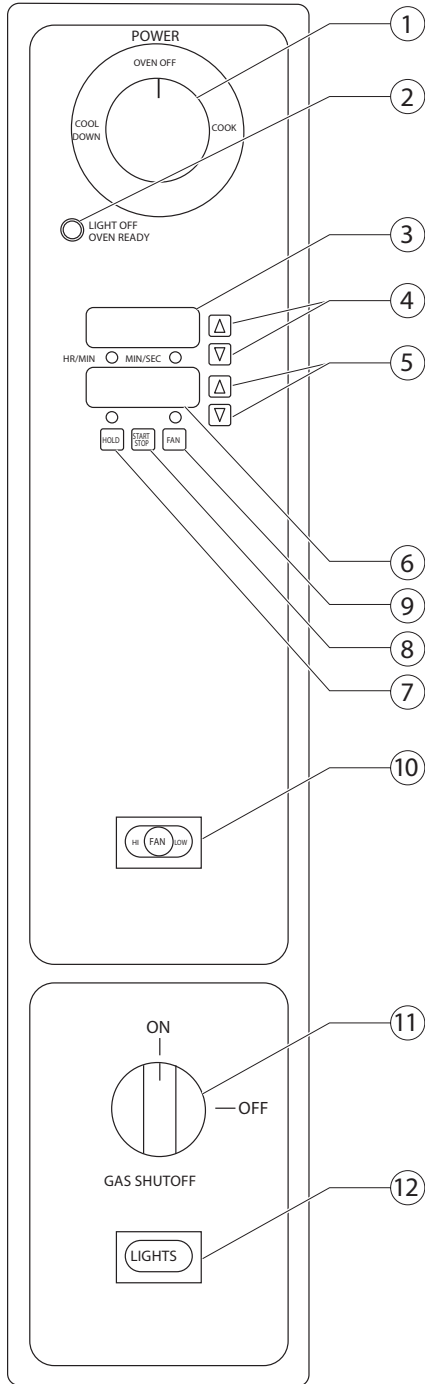

XX Controller – Oven Controls – Solid State Digital

1. **Power Switch:** Controls power to Cook or Cool Down functions.
2. **Indicator Light:** When lit indicates burners or elements are operating. When the light goes out, the oven has reached the desired temperature.
3. **Time Digital display:** Displays time remaining in the chosen cycle.
4. **Time Adjustment buttons:** Sets/Adjusts countdown timer for cook cycle.
5. **Temperature Adjustment Buttons:** Sets/Adjusts cooking temperature.
6. **Temperature Digital Display:** Displays the temperature inside the oven
7. **Hold Button:** Enable/Disables the Hold function.
8. **Start/Stop Button:** Starts/Stops the cooking cycle.
9. **Pulse Fan Button:** Enables/Disables the Pulse Fan function.
10. **Fan Speed Switch:** (Optional) – Sets fan speed to high or low.
11. **Gas OFF/ON Button:** Shuts the gas OFF or turns the gas ON.
12. **Light Switch:** Turns interior lights on/off.

Programming and Operating Instructions – XX Controller

Models with the XX controller enable the oven to cook food at a specified temperature for a specified time period, than enter an optional hold mode. The hold mode holds food at a specified temperature for a specified period of time.

When the power switch is in the ON position the oven will be in one of two modes:

- **Cook Mode:** In this mode the oven operates at a specified temperature and the fan runs continuously, unless the cycle option is selected. In cycle mode the fan runs for 30 seconds and is off for 30 seconds. This cycle continues during the specified cook time.
- **Hold Mode:** In this mode the oven operates at a specified hold temperature; however the fan only runs when the burners are on. If the fan mode switch is in the COOL position the fan will run continuously in the Hold mode.

OPERATING INSTRUCTIONS - continued

To Program Cook Mode do the following:

1. Turn the power switch ON. The power switch is located at the top of the Control Panel.
2. Set the desired cook temperature (150° to 500°F). Use the arrow keys located next to the temperature display. Up raises the temperature, down lowers the temperature.
3. Set the Fan Mode Switch to the Cook position. In the Cook position the fan will not run when the doors are open. If the Fan Mode Switch is set in the COOL position the fan WILL run when the doors are open.
4. If fan cycling is desired press the FAN button. In this mode the fan runs for 30 seconds and is off for 30 seconds. The fan indicator light will blink when the fan is in cycle mode. It stays on steady when the fan is in continuous run mode.
5. Select the correct fan speed for the item being cooked. The Fan Speed switch has two speeds, HI or LOW.
6. Set the desired cook time by using the up and down arrows next to the cook time display. Up increases time, down decreases time.
7. If the Hold Mode is going to be used for the product being cooked, press the HOLD button. The temperature display now displays the Hold temperature. Use the up and down arrows to set the desired holding temperature.
8. Wait until the temperature display stops flashing, when it stops flashing the oven has reached the set temperature. The oven also beeps once to alert the user that it is ready.
9. Place the product to be cooked into the oven and press the START/STOP button. The time display begins counting down the remaining cook time. If the oven doors are opened during the cook cycle, the timer will pause, the fan will shut off and the burners will shut off. The cook cycle will resume when the doors are closed.

For ovens equipped with an interior light, the light may be turned on by pressing and holding the LIGHTS button at the bottom of the Control Panel.

The cook time, oven temperature and fan cycle mode can be changed during the cook cycle as needed.

To cancel a cook cycle press, the START/STOP button.

10. If the HOLD mode is NOT enabled the oven begins beeping and the display will flash "00" indicating the cook cycle is complete. Press the START/STOP button to silence the alarm and immediately remove the product from the oven. **If the oven doors are shut the oven will maintain the set cook temperature even though the timer has run out.** To cool down the product, open the doors, with the Fan Mode to COOL and change the FAN SPEED to HI.

If the HOLD mode IS enabled the oven will beep three times when the cool time has completed. The timer will begin an upward count, indicating how long the product has been holding. The temperature display now displays the holding temperature. The oven will remain in HOLD mode until the START/STOP button is pressed. Pressing the START/STOP button returns the oven to the COOK mode.

11. When cooking is completed press the Power ON/OFF button to turn the oven off.

GENERAL GUIDELINES FOR OPERATION

These guidelines are to assist you in obtaining the best performance from your oven:

- Always pre-heat your oven before cooking by placing the temperature setting at the desired temperature. The oven is pre-heated when the Indicator Light goes out.
- Always use a lower temperature setting than that recommended for a standard conventional oven or range oven. The general rule of thumb is to subtract 50 - 100°F from the standard oven recipe. Some experimentation on your part may be necessary to achieve the optimum results with your food products.



OPERATING INSTRUCTIONS - continued

Cooking at higher temperatures will not reduce your cooking time! It will produce unsatisfactory baking and roasting results.

- You should begin checking the doneness of your food product in about half the time recommended for the same recipe cooked in a standard oven. There is a Suggested Time and Temperature Chart on the next page, which can serve as a guide. Keep in mind that your times may vary depending on the amount of product being cooked in your oven. The best results are always achieved when a systematic record of times and temperatures is kept for reference.
- The oven will hold up to thirteen 18" x 26" (457mm x 660mm) sheet pans. Your product and pan height will determine how many racks can be loaded.

Do not place an empty sheet pan or aluminum foil on the bottom of the oven. This will disrupt the airflow and cause uneven cooking results.

- To minimize the shrinkage of roasted meats, place the meat directly on the racks and place a sheet pan one half full of water in the bottom rack position. The water will keep the oven compartment more humid and the meat juices will evaporate less.
- Maintain equal loads when cooking more than one pan of product at a time. You may wish to weigh the product to assure that the pan loads are equal. Smaller loads in one pan will cook at a different rate than larger ones in another.
- You may wish to experiment with leaving the oven OFF after pre-heating the oven and loading when baking light products such as light cake batter or custard so the product will have time to set. Normally, 7-10 minutes with the oven OFF, then finishing with the oven ON, will keep the product from rippling or being pushed by the fan.
- When starting off with frozen product, you may wish to pre-heat your oven up to 100° F above the temperature you are going to cook. Load the product and reset the temperature for the normal time.
- For longer bulb life, do not leave the oven lights on when not viewing the product.

IMPORTANT NOTE: When an oven is supplied on casters and is connected to the supply piping by means of a connector for movable appliances, the oven must be equipped with a restraint and, if disconnection of the restraint is necessary, reconnect this restraint after the oven has been returned to its originally installed position.

CLEANING OF THE OVENS

The stainless steel on your oven can be kept clean with a good stainless steel cleaner, many of which are on the market. The painted surfaces should be wiped clean regularly with a MILD detergent. Moisten a cloth and wipe down the oven while it is COLD. Wiping down an oven while it is hot will cause streaking and otherwise unsatisfactory results. Once the oven is clean it can be wiped down with light oil.

Porcelain oven interiors should be cleaned regularly using a degreasing agent. For heavier deposits a commercial oven cleaner such as Dow Oven Cleaner, Easy-Off, or Mr. Muscle can be used. Care must be taken to prevent these alkaline-type cleaners from coming in contact with any aluminized steel surfaces in the oven, including the blower wheel.

The blower wheel, racks and rack supports can be removed and soaked in a solution of ammonia and water.

⚠ WARNING

Disconnect the power supply to the appliance before removing blower wheel.

Make certain that all parts are thoroughly rinsed before returning to use.

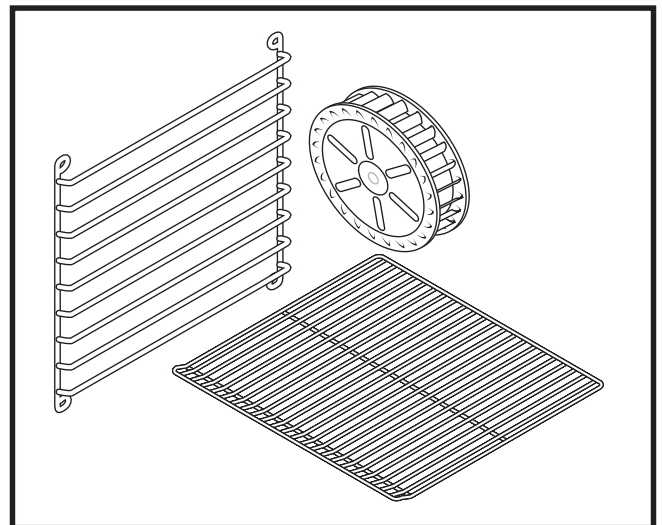

SUGGESTED COOK TIMES & TEMPERATURES

	PRODUCT	°F	°C	COOK TIME	RACKS	TEMP	TIME
BEEF	HAMBURGER PATTIES (3.3 OZ.)	400	205	8-10 MIN.	13		
	MEAT LOAF	325	165	40-45 MIN.	4		
	STEAMSHIP ROUND (80 LBS. QUART.)	275	135	2-3/4 HRS. F	2		
	ROLLED BEEF ROAST (12-15 LBS.)	275	135	2-1/2 HRS.	4		
	STANDING RIB ROAST (20 LBS. RARE)	235	115	2-3/4 HRS.	2		
	SHELL STEAKS (100Z.)	450	230	7-8 MIN.	6		
	POT PIES	400	205	30-35 MIN.	6		
	STUFFED PEPPERS	350	175	15-20 MIN.	4		
	LASAGNA	260	125	90 MIN.	4		
	HOT DOGS	325	165	10-15 MIN.	6		
PORK	BAKED, STUFFED PORK CHOPS	375	190	25-30 MIN.	6		
	BACON	400	205	5-7 MIN.	13		
VEAL	BONED VEAL ROAST (15 LBS.)	300	150	3 HRS. 10 MIN.	3		
LAMB	LAMB CHOPS	400	205	7-8 MIN.	6		
POULTRY	CHICKEN BREASTS & THIGHS	350	175	40 MIN.	6		
	CHICKEN BACKS & WINGS	350	175	35 MIN.	6		
	CHICKEN, QUARTERED	350	175	30 MIN.	6		
	TURKEY ROLL (18 LB.)	310	155	3-3/4 HRS.	4		
	POT PIES	400	205	30-35 MIN.	6		
FISH	FISH STICKS	335	170	16-18 MIN.	13		
SEAFOOD	COD, HALIBUT (FROZEN)	350	175	20 MIN.	6		
	SHRIMP, BAKED STUFFED	400	205	6-7 MIN.	6		
	LOBSTER, BAKED STUFFED	400	205	10 MIN.	4		
	LOBSTER TAILS (FROZEN)	425	220	9 MIN.	6		
CHEESE	MACARONI & CHEESE CASSEROLE	350	175	30 MIN.	6		
	CHEESE SANDWICHES, GRILLED	400	205	8 MIN.	13		
POTATOES	POTATOES, BAKED (120 COUNT)	400	205	50 MIN.	6		
	POTATOES, SLICED OR DICED	325	165	10 MIN.	6		
	FRENCH FRIES (FROZEN)	TIMES & TEMPS WILL VARY AS TO CUT					
PIES	FROZEN BERRY PIES (36 - 22 OZ. EA.)	325	165	35 MIN.	6		
	FROZEN FRUIT PIES (24 - 46 OZ. EA.)	325	165	45-50 MIN.	6		
	FRESH APPLE PIE (36 - 20 OZ. EA.)	350	175	25-30 MIN.	6		
	PUMPKIN PIE	300	150	30-50 MIN.	6		
	FRUIT CRISP	300	150	25 MIN.	6		
	FRUIT COBBLER	300	150	30 MIN.	6		
	APPLE TURNOVERS	350	175	15 MIN.	6		
	BREADS	BREAD (32 -1 LB. LOAVES)	325	165	30 MIN.	4	
CORN BREAD (NORTHERN)		325	165	25 MIN.	6		
CORN BREAD (SOUTHERN)		375	190	15-20 MIN.	6		
HAMBURGER ROLLS		275	125	15 MIN.	6		
YEAST ROLLS		300	140	25 MIN.	6		
BISCUITS		400	205	6 MIN.	6		
ROLLS, BROWN & SERVE		350	175	15 MIN.	6		
CAKES	SHEET CAKES (5 LBS. BATTER PER PAN)	325	165	16-18 MIN.	6		
COOKIES	CHOCOLATE CAKE	325	165	20 MIN.	6		
	BROWNIES	325	165	15 MIN.	6		
	DANISH PASTRY	325	165	12 MIN.	6		
	CINNAMON BUNS	325	165	20 MIN.	6		
	SUGAR COOKIES	275	125	15 MIN.	13		
	CREAM PUFFS	325	165	20-25 MIN.	6		
	CHOCOLATE CHIP COOKIES	325	165	10 MIN.	13		
	PEANUT BUTTER COOKIES	300	150	10 MIN.	13		

NOTE: Your times and temperatures may vary from those shown on this chart. Your results depend on weight per pan, temperature of the product before loading, the recipe, type of pan, and calibration of the thermostat. If your recipes vary from these, write in your proven times and temperatures for your future use.



MAINTENANCE INSTRUCTIONS

⚠ WARNING: Disconnect the power supply to the appliance before servicing.

⚠ WARNING: Units provided with casters have a restraint to limit the movement of the oven. If this restraint is disconnected during servicing it must be reconnected after the appliance has been returned to its original installed position.

Note: Proper clearances must be maintained during servicing.

These maintenance instructions are for the use of qualified service personnel only. Service by other than qualified personnel may result in damage to the oven and/or injury to the operator.

Qualified service personnel are those individuals, firms, companies or corporations which either in person or through an agent are engaged in and responsible for repair or servicing of commercial food preparation equipment, who are experienced in such work, familiar with all precautions required, and have complied with all requirements of state and local authorities having jurisdiction.

If you require assistance in the selection of a qualified service agency, please contact Duke Manufacturing Co.'s Service Department at 800-735-3853.

A. ADJUSTMENTS

Quite often malfunctions, which are attributed to defects, may be repaired by adjusting certain parts rather than replacing them.

B. DOOR ADJUSTMENT

6/13 Series Convection Ovens (except model option Q) have doors that are inter-connected so they operate simultaneously by means of a chain and turnbuckle assembly. The doors are properly adjusted and inspected before the oven leaves the factory. However, from time to time it may become necessary to readjust the doors after usage. If you find it necessary to adjust the doors for proper operation, the chain and turnbuckle assembly is located behind the panel that is over the doors. It is best to adjust turnbuckles while the door is in an unlatched position.

- Loosen the jam nut on both turnbuckles.
- Make adjustments simultaneously to both turnbuckles.
- Loosening or tightening the assembly will not allow the doors to work properly. Ideally, you should loosen one turnbuckle and tighten the other. Some experimentation will indicate which direction you will want to make your adjustments.
- Once the doors are operating properly, retighten the jam nuts so the unit will stay in adjustment. Test the door to make certain it is in adjustment.
- Replace cover.

C. DOOR SWITCH ADJUSTMENT

You may also wish to adjust the door switch. The door switch is located behind the combustion compartment cover, on the right side. The door switch is activated by a cam, which is mounted to the door's hinge pin with a setscrew.

- Open the doors fully.
- Remove the lower cover by loosening the four screws located inside the door opening.
- Position the doors so they are nearly closed but not latched.
- To adjust the cam loosen the setscrew and rotate the cam until you hear the switch click.
- Tighten the setscrew in the cam. Test the door to make certain the switch will make contact with the doors closed.
- Torque setscrew to 60 in-lbs.
- Replace the combustion cover.

⚠ WARNING: The door turnbuckles and door switch are located in a heated zone. Care should be taken to avoid burns.

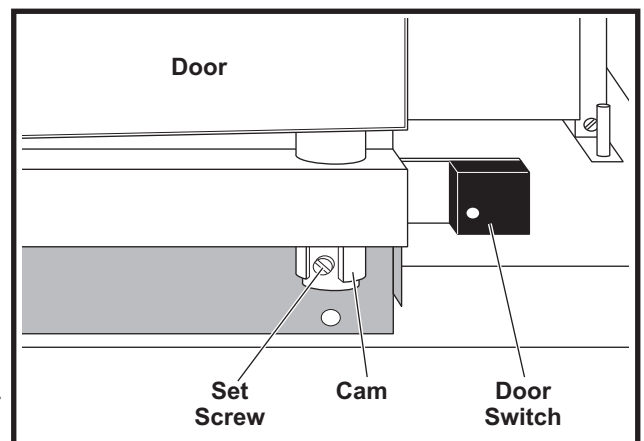

MAINTENANCE INSTRUCTIONS - continued

THERMOSTAT CALIBRATION

Electro-Mechanical Controls Only ("V"). Not applicable to Ovens with Solid State Controls.

In many convection ovens thermostats have been the cause of more operating problems than any other component part. Thermostats, being mechanical devices, do sometimes fail, in which case only replacing the part will correct the problem. However, the great majority of thermostat related problems could be attributed to their being out of adjustment (calibration). A thermostat that is out of calibration may cause unsatisfactory cooking results such as uneven baking, prolonged cooking times, etc. If you are experiencing uneven cooking, it may be a result of excessive cooking temperatures. Refer to the cooking chart provided in Operating Instructions Section C.

To Check Calibration:

- Turn the oven on by turning the Power Switch to the ON position.
- Open the doors and place a thermocouple in the center of the middle oven rack. A reliable mercury-type thermometer can be substituted if a pyrometer is not available.
- Turn the thermostat dial to 350°F (177°C). Allow the oven to preheat 1/2 hour.
- When the indicator light goes out, the thermostat has been satisfied. Check the pyrometer or thermometer to determine the internal oven temperature.
- If the reading on the pyrometer (or thermometer) is less than 10°F different from the setting of the thermostat, no adjustment is needed. If this reading is more than 10°F, proceed with calibration procedure.

To Calibrate the Ovens

- Remove the thermostat knob by loosening the setscrew and pull the knob forward. Take care not to rotate the thermostat stem, which will change the setting.
- With a very small screwdriver, turn the screw located in the bottom of the hollow of the stem clockwise to lower the temperature or counterclockwise to raise the temperature. **DO NOT** allow the stem of the thermostat to rotate as you turn the screw.

- Open the door and turn the POWER SWITCH to the COOL DOWN position. This will allow the oven fan to come on without the burners and cool off the oven. Allow the oven to cool to about 250°F (120°C).
- Return the **POWER SWITCH** to the **ON** position and repeat the previous steps until the oven thermostat and the pyrometer (thermometer) reading agree.
- Replace the knob and tighten the setscrews.

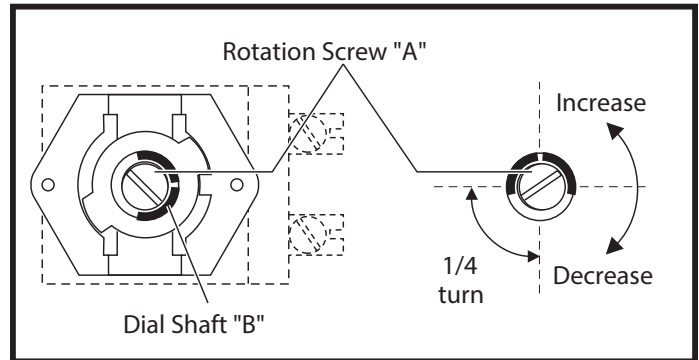

NOTICE Maximum turn of screw "A" is 1-1/2 turns – clockwise or counter-clockwise.

This thermostat is a direct-acting (opens on temperature rise) device.

E. GAS PRESSURE REGULATION AND ADJUSTMENT

The gas pressure has been preset at the factory for the type of gas specified on the rating plate; however, it is sometimes necessary to adjust the gas pressure after the unit has been installed.

- Turn the Gas Shut Off Valve to the OFF position.
- Remove the Control Panel by removing the screw at the top overhang above the panel.
- Pull the Control Panel forward and lay aside. **Do not remove any wiring.**
- Remove the Combustion Compartment Cover by removing the screws located in the bottom of the door opening.
- Find the pressure tap located at the lower right hand corner of the unit on the Right hand side of a plumbing "Tee". The pressure tap is a 1/8" pipe plug with a hex head.
- Remove the pressure tap plug and replace with the fitting for a gas pressure meter, slack tube or manometer.

MAINTENANCE INSTRUCTIONS - continued

- Attach your meter.
- The pressure regulator is an integral part of the dual solenoid gas valve. Locate the adjustment screw on the left hand side. (It has a slotted aluminum cover cap.)
- Remove the cover cap.
- Open the Gas Shut Off Valve.
- Turn the Main power switch to the COOK position.
- With the burner on, check your meter. The manifold pressure should be 3.5" W.C. for natural gas and 10" W.C. for propane.
- Check the rating plate to verify gas types and pressures.

NOTE: It is important to check the gas pressure of any unit while ALL the equipment on that gas line is ON. This will tell you if you have a properly sized gas delivery system or if there is a problem with gas volume. If you experience a pressure drop that does not recover when the other equipment is turned on, you should look for problems in the size of the pipes or some other type of restriction. Refer to the chart on Maximum Capacity of Pipes located in Section II.D.

- Rotate screw inside, Clockwise to increase pressure, Counter-clockwise to decrease pressure.
- When the proper pressure is attained, turn the power switch to the OFF position and close Manual Shut Off Valve.
- Remove your meter and Fitting. Replace pressure tap plug. (You may need to add some pipe dope to the plug to prevent a leak.)
- Turn the power switch to the ON position and open the Manual Shut Off Valve.
- With a solution of soapy water, check for gas leaks. Repair any leaks.
- Replace cover cap on gas valve.
- Replace Combustion Cover.
- Replace Control Panel.

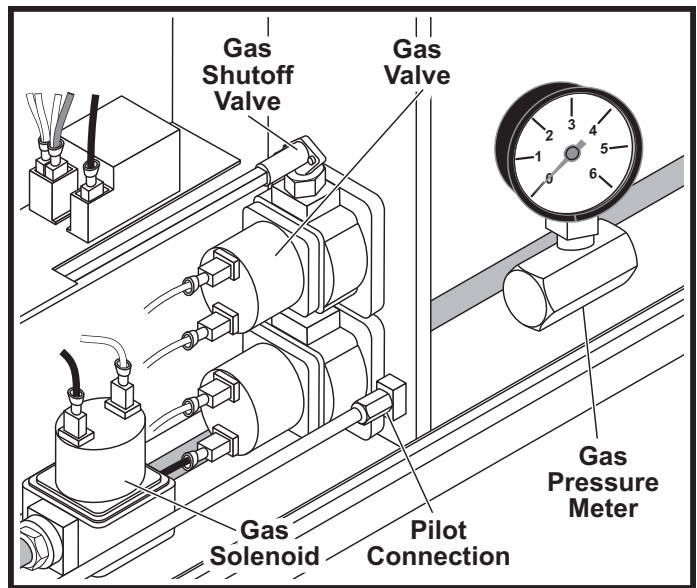

F. VENTILATION SYSTEM

It is important that the ventilation system be inspected and/or maintained by Qualified Personnel at least once each year.

This inspection/maintenance should consist of, but not be limited to:

- Inspection for blockages or build up which might interfere with the venting of the oven.
- Repair of such blockages.
- Proper installation of the draft hood or flue guard.
- Inspection of the venting canopy, its drive motors and belts, etc.

Proper preventive maintenance can reduce your chances of costly repairs.

ELECTRICAL SCHEMATIC GAS CONVECTION OVEN

P.N. 153619 Rev.F

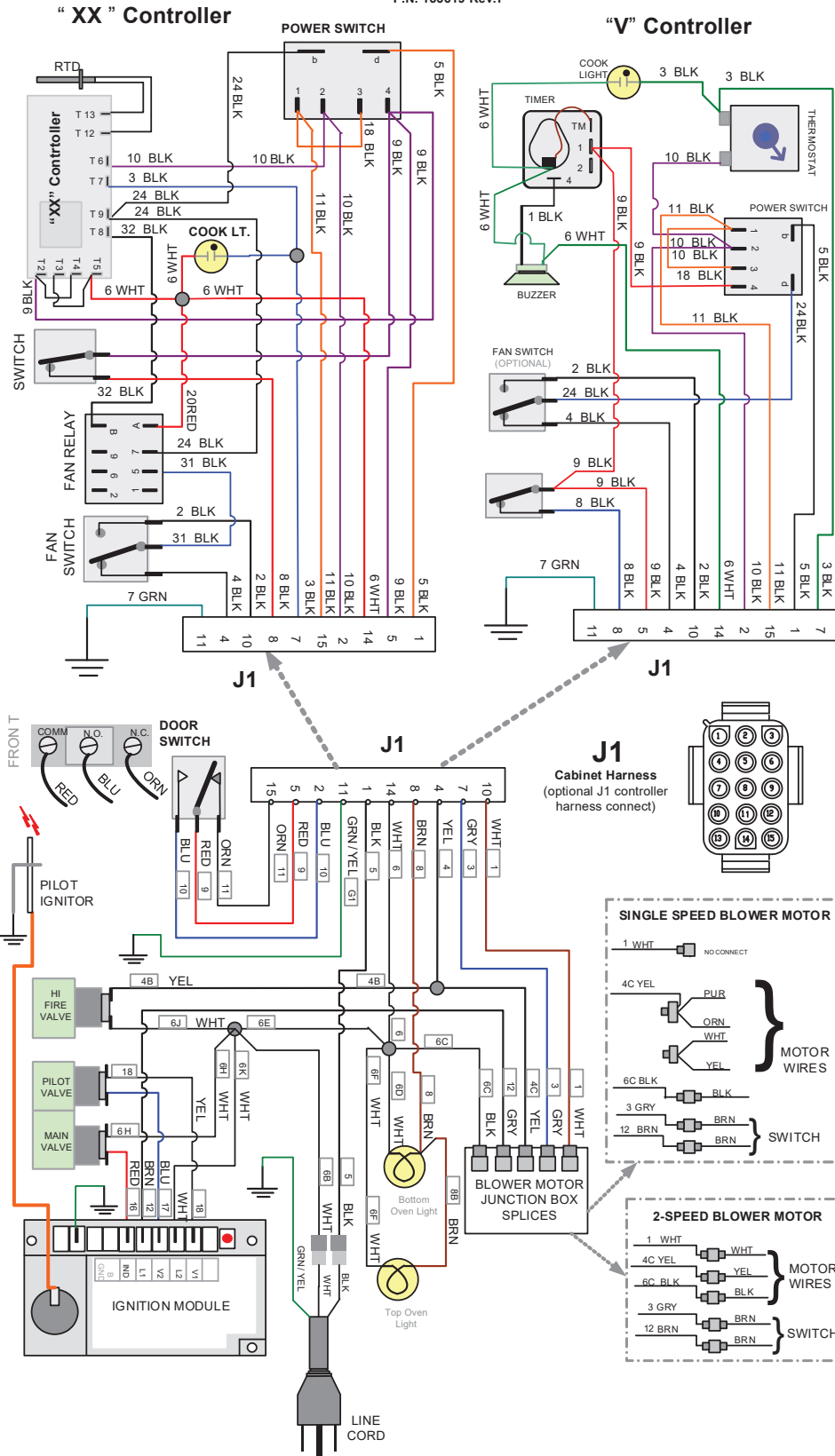

Duke Manufacturing Co.
2305 N. Broadway
St. Louis, MO 63102

Phone: 314-231-1130
Toll Free: 1-800-735-3853
Fax: 314-231-5074

www.dukemfg.com