

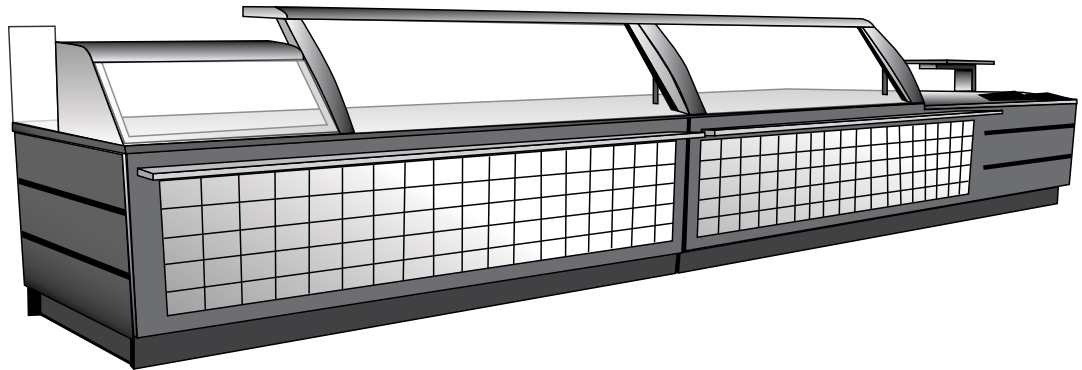

Your Solutions Partner

# Illustrated Parts List



## SUBWAY<sup>®</sup> FRONT COUNTER

### MODEL

SUB-CP-TC

SUB-HF

SUB-CU

---

This manual is Copyright ©2019 Duke Manufacturing Co. All rights reserved.  
Reproduction without written permission is prohibited. Duke is a registered  
trademark of the Duke Manufacturing Co.

### Duke Manufacturing Co.

2305 N. Broadway  
St. Louis, MO 63102  
Phone: 314-231-1130  
Toll Free: 1-800-735-3853  
Fax: 314-231-5074  
[www.dukemfg.com](http://www.dukemfg.com)



## TABLE OF CONTENTS

HOW TO DETERMINE MANUFACTURE DATE FROM DUKE EQUIPMENT SERIAL NUMBERS..... 3

TRI-CHANNEL – COLD PAN ..... 4  
    Figure: PL-1 Tri-Channel – Cold Pan ..... 4  
    Table: PL-1 Tri-Channel – Cold Pan ..... 5

PURSE RAIL – FRONT COUNTER..... 6  
    Figure: PL-2 Purse Rail – Front Counter ..... 6  
    Table: PL-2 Purse Rail – Front Counter ..... 7

TRI-CHANNEL – COMPRESSOR ASSEMBLY..... 8  
    Figure: PL-3 Tri-Channel Compressor Assembly ..... 8  
    Table: PL-3 Tri-Channel Compressor Assembly..... 8

HOT FOOD PAN..... 12  
    Figure: PL-4 Hot Food Pan ..... 12  
    Table: PL-4 Hot Food Pan..... 12

ALUMINUM DAY COVER – TRI-CHANNEL COLD PAN ..... 13  
    Figure: PL-5 Aluminum Day Cover – Tri-Channel Cold Pan..... 13  
    Table: PL-5 Aluminum Day Cover – Tri-Channel Cold Pan ..... 13

ALUMINUM DAY COVER – HOT FOOD PAN..... 15  
    Figure: PL-6 Aluminum Day Cover – Hot Food Pan..... 15  
    Table: PL-6 Aluminum Day Cover – Hot Food Pan ..... 15

STAINLESS STEEL DAY COVER – TRI-CHANNEL COLD PAN and HOT PAN UNITS..... 18  
    Figure: PL-7 Stainless Steel Day Cover – Tri-Channel Cold Pan and Hot Pan Units ..... 18  
    Table: PL-7 Stainless Steel Day Cover – Tri-Channel Cold Pan and Hot Pan Units..... 18

## How to Determine Manufacture Date from Duke Equipment Serial Numbers

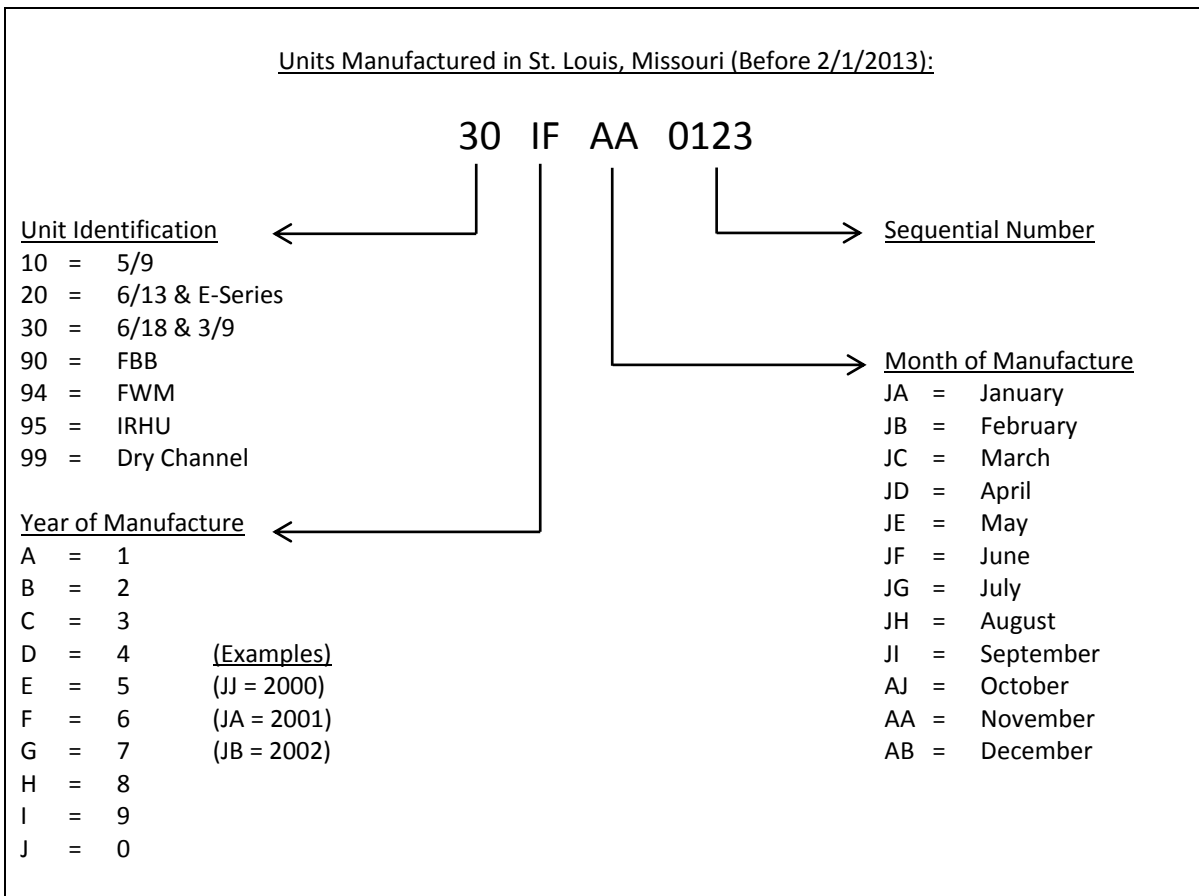
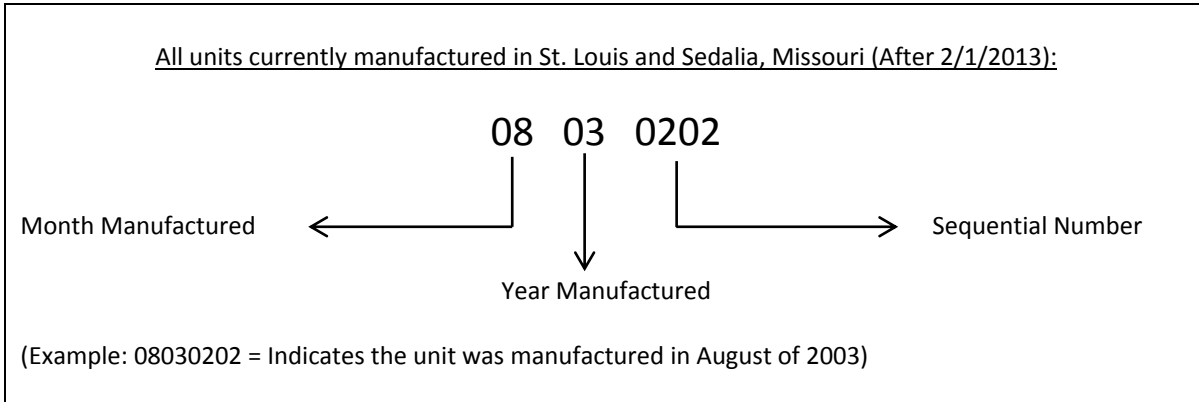



### TRI-CHANNEL – COLD PAN

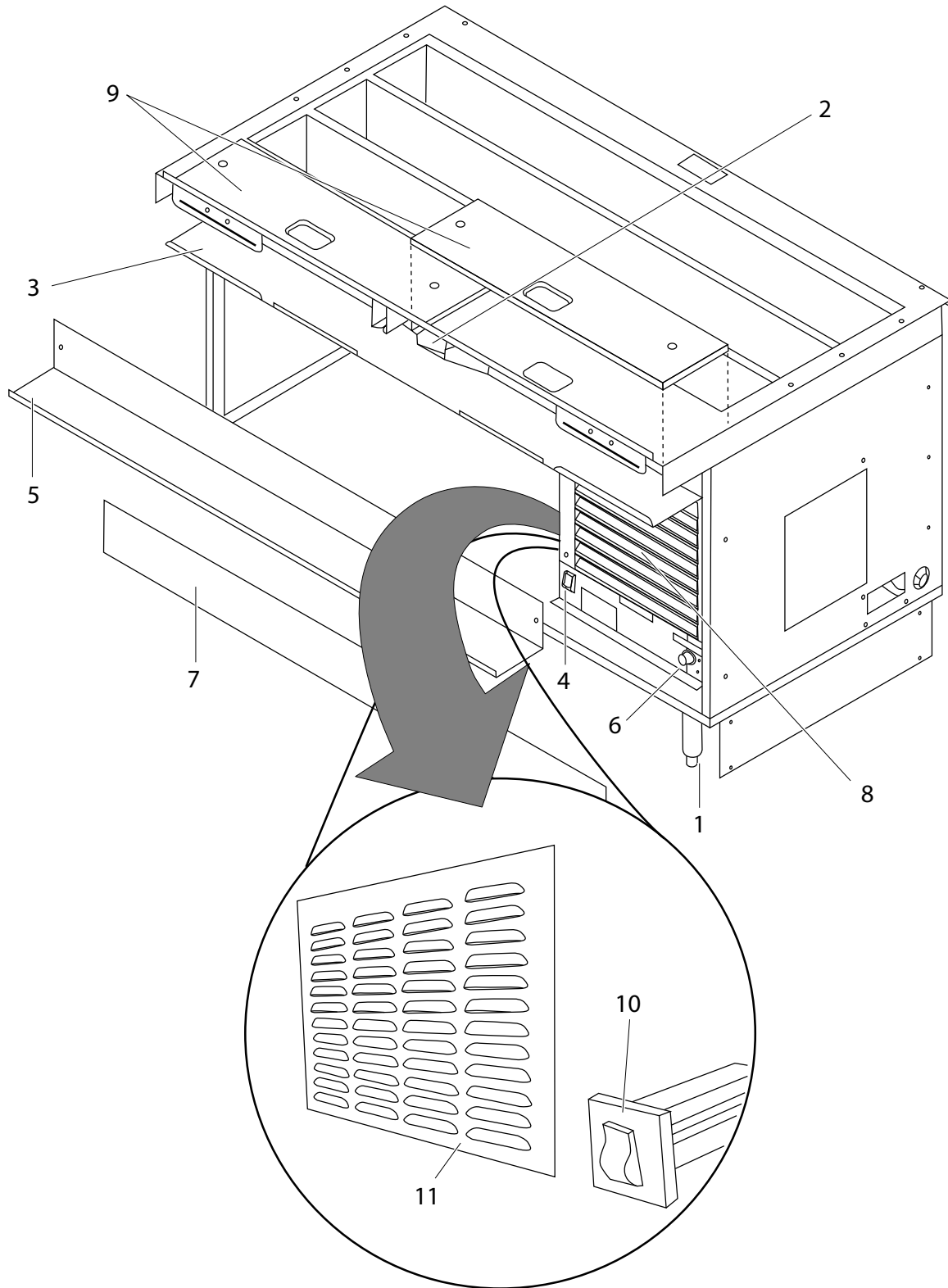

Figure: PL-1 Tri-Channel – Cold Pan

## TRI-CHANNEL – COLD PAN

ITEM	QTY.	PART NUMBER	DESCRIPTION
1	4/6	214556	Leg Assembly, Galvanized, 1 <sup>5</sup> / <sub>8</sub> " x 6"
2	1/2	252893KIT	Kit, Assembly, Knife Holder
3	1	253477	Shelf, Supply Cold Pan 48" w/Brackets
	1	253478	Shelf, Supply Cold Pan 60" w/Brackets USED UNTIL 12/16/07
	1	253480	Shelf, Supply Cold Pan 74" w/Brackets
	1	253481	Shelf, Supply Cold Pan 86" w/Brackets
	1	RS022480	Cold Pan Funct. Shelf Assembly 48" One Piece USED 12/17/07 & AFTER
	1	RS022481	Cold Pan Funct. Shelf Assembly 60" One Piece (Upper/Lower Together)
	1	RS022482	Cold Pan Funct. Shelf Assembly 74" One Piece
	1	RS022483	Cold Pan Funct. Shelf Assembly 86" One Piece
4	1	212280	Switch, Lighted, Amber (Master Power)
5	1	252341	Shelf, Supply Auxiliary 48" Cold Pan
	1	252264	Shelf, Supply Auxiliary 60" Cold Pan USED UNTIL 12/16/07
	1	252356	Shelf, Supply Auxiliary 74" Cold Pan
	1	252171	Shelf, Supply Auxiliary 86" Cold Pan
6	1	216837	Thermostat, 120VAC Digital Elreha TXV USED 9/17/07 & AFTER
	1	216588	Thermostat, 220VAC Digital Elreha TXV USED 9/17/07 & AFTER
	1	226837	Probe, Digital Elreha TXV USED 9/17/07 & AFTER
	1	SUB-DIXEL-REPL	Kit, Replace 216814 T-Stat--SO Specs used on 220/50 Tri-Channel
	1	216812	Probe, International 220V Dixell USED AFTER 3/13/06
	1	254787	Thermostat Kit, SW N7 Coldpan 220VAC, 50Hz USED UNTIL 6/2002
	1	216534	Knob for 216437 Thermostat (included with 254787 Kit)
	1	4788-2	Kit, Replacement Thermostat (June 2002 to September 2007)
7	1	RS000234	Kick Plate Assembly - 36"
	1	RS000235	Kick Plate Assembly - 48"
	1	RS000236	Kick Plate Assembly - 60"
	1	RS000239	Kick Plate Assembly - 74"
	1	RS000240	Kick Plate Assembly - 86"
8	1	252313	Louver Compressor Cold Pan USED UNTIL 4/6/06
	1	255032	Panel, Louver Tri-channel with Keyholes USED 4/7/06 & AFTER
9	1	215332	Unit Carving Board, 48" x 8" Day Cover
	2	215333	Unit Carving Board, 60" x 8" Day Cover
	2	215334	Unit Carving Board, 74" x 8" Day Cover
	2	215335	Unit Carving Board, 86" x 8" Day Cover
Not Shown	A/R	214728	Position Stud, SS 1/4-20 x 7/16"
10	1	212309	2 Amp Circuit Breaker, Purse Rail Lights
Not Shown	1	222287	Module, Power Entry
11	1	255031	Panel, Compressor Side Louvre USED 4/7/06 & AFTER
Not Shown	1	216499	Thermostat - Used Prior to 11/1/95
Not Shown	A/R	216578	Sealant, 108 RTV, Gray
Not Shown	A/R	254041KIT	Adaptor Bottle Holder Sixth Size

Table: PL-1 Tri-Channel – Cold Pan

### PURSE RAIL – FRONT COUNTER

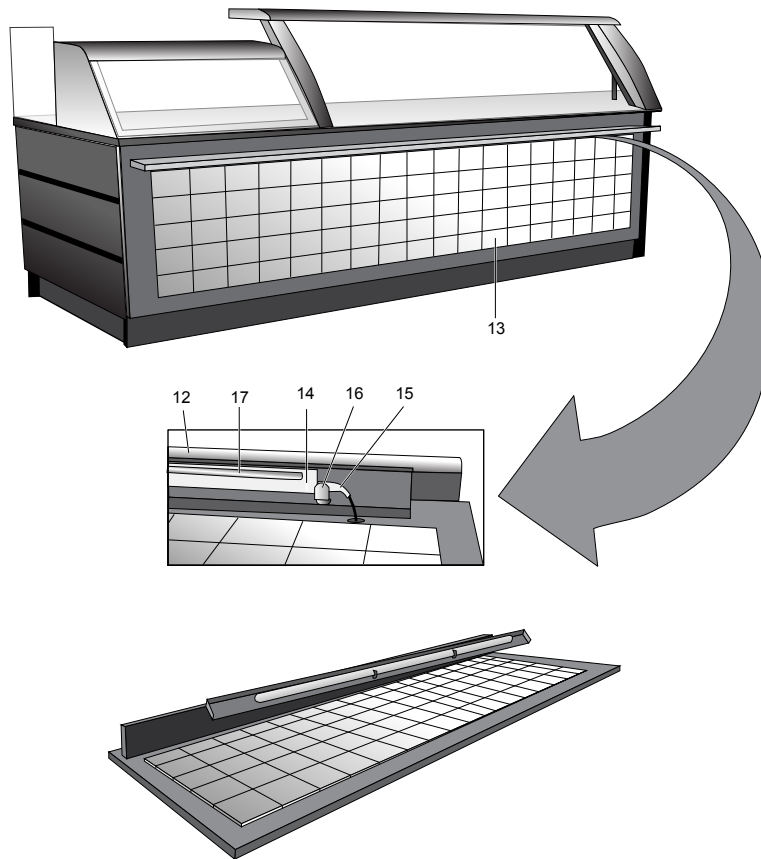

Figure: PL-2 Purse Rail – Front Counter

ITEM	QTY.	PART NUMBER	DESCRIPTION
12	1	SUB-REPL-PR-LT	Subway Replacement Purse Rail Kit – Left
	1	SUB-REPL-PR-RT	Subway Replacement Purse Rail Kit – Right
	1	SUB-REPL-PR-SGL	Subway Replacement Purse Rail Kit – Single
	1	SUB-PR-CVR-SET	Kit, SS Purse Rail Left/Right Covers ( <i>Set of two</i> )
	1	SUB-PR-CVR-SGL	Kit, SS Purse Rail Single Cover
13	A/R	216221	Tile, Mosaic Left/Veggie, Rectangle Basket ( <i>Used Until 10/2008</i> )
		216222	Tile, Mosaic Right/Veggie, Round Basket ( <i>Used Until 10/2008</i> )
		226221	Panel, Pepper ( <i>Used After 11/2008</i> )
		226222	Panel, Tomato ( <i>Used After 11/2008</i> )
<b>HERA T4 LIGHT FIXTURES, REPLACEMENT BULBS, CORDS &amp; CONNECTORS (<i>Used Until 9/2006</i>)</b>			
14	A/R	SUB-HERAFIXT120	Light Fixture-19", T4 Fluorescent-HERA, 18W-120V
	A/R	0652010	Light Fixture-19", T4 Fluorescent-HERA, 18W-220V
15	1	212202	Hera Cord with Plug, 120VAC
	1	214303	Hera Cord with Plug, 220VAC
		225812	Hera Cord with Plug, 120VAC ( <i>New</i> )
16	A/R	251836	T4 Clip, Light Fixture Mounting, Purse Rail ( <i>Old</i> )
17	A/R	0651428	Bulb, T4 Fluorescent-HERA, 18W-120/220V
Not Shown	A/R	214432	Hera, Connector, Direct Light Fixture, 120VAC
	A/R	212305	Hera, Connector, Pin to Pin, 220VAC

## PURSE RAIL – FRONT COUNTER

**LITE CO T4 LIGHT FIXTURES, REPLACEMENT BULBS AND CORDS (Used After 9/2006)**

14	A/R	215820	Light Fixture-20.6", T4 Fluorescent-LITECO, 16W-120V
	A/R	215853	Light Fixture-20.6", T4 Fluorescent-LITECO, 16W-220V
15	1	215886	LITECO, Cord with Plug, 110VAC, 6 ft.
	1	215887	LITECO, Cord with Plug, 220VAC, 6 ft.
16	A/R	251836	T4 Clip, Light Fixture Mounting, Purse Rail
17	A/R	215883	Bulb, T4 Fluorescent-LITECO, 16W-120V
	A/R	215855	Bulb, T4 Fluorescent-LITECO, 16W-220V

**HERA T5 LIGHT FIXTURES, REPLACEMENT BULBS, CORDS & CONNECTORS (Used After 2/2009)**

14	A/R	225800	Light Fixture-12, T5 Fluorescent-HERA, 8W-120V
	A/R	225801	Light Fixture-24, T5 Fluorescent-HERA, 14W-120V
	A/R	225802	Light Fixture-36, T5 Fluorescent-HERA, 21W-120V
	A/R	225803	Light Fixture-48, T5 Fluorescent-HERA, 28W-120V
	A/R	225804	Light Fixture-12, T5 Fluorescent-HERA, 8W-230V
	A/R	225805	Light Fixture-24, T5 Fluorescent-HERA, 14W-230V
	A/R	225806	Light Fixture-36, T5 Fluorescent-HERA, 21W-230V
	A/R	225807	Light Fixture-48, T5 Fluorescent-HERA, 28W-230V
15	1	225812	Hera Cord with Plug, 120VAC
	1	225813	Hera Cord with Plug, 230VAC EU
16	A/R	225824	Clip, Light Fixture Mounting, Purse Rail ( <i>T5 Fixtures</i> )
17	A/R	225808	Bulb, T5 Fluorescent-HERA, 8W-120/230V
	A/R	225809	Bulb, T5 Fluorescent-HERA, 14W-120/230V
	A/R	225810	Bulb, T5 Fluorescent-HERA, 21W-120/230V
	A/R	225811	Bulb, T5 Fluorescent-HERA, 28W-120/230V
Not Shown	A/R	SUB-T5LTS-G120	Assembly, Light Kit, Purse Rail, 120VAC
Not Shown	A/R	SUB-T5LTS-G220	Assembly, Light Kit, Purse Rail, 230VAC

**FEELUX SSL LIGHT FIXTURES, CORDS & JUMPERS (Used After 8/2011)**

14	A/R	225950	Light Fixture-12, LED SSL 120V
	A/R	225951	Light Fixture-24, LED SSL 120V
	A/R	225770	Light Fixture-36, LED SSL 120V
	A/R	225952	Light Fixture-48, LED SSL 120V
	A/R	225960	Light Fixture-12, LED SSL 230V
	A/R	225961	Light Fixture-24, LED SSL 230V
	A/R	225972	Light Fixture-36, LED SSL 230V
	A/R	225962	Light Fixture-48, LED SSL 230V
15	1	225963	Cord, Power SSL 120V
	1	225964	Cord, Power SSL 230V
Not Shown	A/R	225965	Jumper, Power SSL 120V
Not Shown	A/R	225966	Jumper, Power SSL 230V

**HERA SSL LIGHT FIXTURES, CORDS & JUMPERS (Used After 4/2016)**

14	A/R	225768	Light Fixture-12, LED SSL 120V
	A/R	225769	Light Fixture-24, LED SSL 120V
	A/R	225770	Light Fixture-36, LED SSL 120V
	A/R	225771	Light Fixture-48, LED SSL 120V
	A/R	225773	Light Fixture-12, LED SSL 230V
	A/R	225774	Light Fixture-24, LED SSL 230V
	A/R	225775	Light Fixture-36, LED SSL 230V
	A/R	225776	Light Fixture-48, LED SSL 230V
15	1	225772	Cord, Power SSL 120V
	1	225777	Cord, Power SSL 230V
Not Shown	A/R	225778	Jumper, Power SSL 120/230V

Table: PL-2 Purse Rail – Front Counter

### TRI-CHANNEL – COMPRESSOR ASSEMBLY

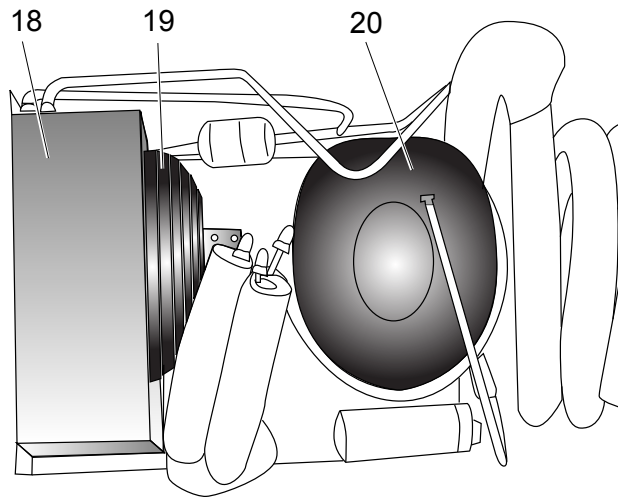

Figure: PL-3 Tri-Channel Compressor Assembly

ITEM	PART NO	DESCRIPTION	QTY
<b>CONDENSING UNITS USED FROM 6/2003 THROUGH 9/12/2006</b>			
18	216453	Cond Unit, 48 & 60" Tri-Cap, 60Hz <i>(Replaced by 216879)</i>	1
19	217808	Fan Motor for 216453 Condensing Units	1
20	527844	Compressor for 216453 Condensing Units	1
Not Shown	217813	Protector for 216453 Condensing Units	1
Not Shown	217883	Relay for 216453 Condensing Units	1
Not Shown	217843	Start Cap for 216453 Condensing Units	1
Not Shown	217809	Fan Blade for 216453 Condensing Units	1
Not Shown	216820	Valve, Auto Expansion, 3 Circuit Distribution	1
Not Shown	SUB-TRI-AXV-KIT	Kit, Cap Tube to AXV, Conversion	1
<b>CONDENSING UNITS USED FROM 6/2003 THROUGH 9/6/2006</b>			
18	216457	Condensing Unit, Assembly, 48 & 60 Inch Tri-Cap, 50Hz	1
19	217846	Fan Motor for 216457 Condensing Units	1
20	217845	Compressor for 216457 Condensing Units	1
Not Shown	217849	Protector for 216457 Condensing Units	1
Not Shown	217848	Relay for 216457 Condensing Units	1
Not Shown	217847	Start Cap for 216457 Condensing Units	1
Not Shown	217809	Fan Blade for 216457 Condensing Units	1
Not Shown	216820	Valve, Auto Expansion, 3 Circuit Distribution	1
Not Shown	SUB-TRI-AXV-KIT	Kit, Cap Tube to AXV, Conversion	1
<b>CONDENSING UNITS USED FROM 6/2003 THROUGH 9/13/2006</b>			
18	KIT-COND-TRI382	Condensing Unit, Assembly, 74 & 86 Inch Tri-Cap, 60Hz	1
19	217851	Fan Motor for 216454 Condensing Units	1
20	217850	Compressor for 216454 Condensing Units	1
Not Shown	217855	Protector for 216454 Condensing Units	1
Not Shown	217885	Relay for 216402 Or 216882 Condensing Units	1
Not Shown	217853	Start Cap for 216454 Condensing Units	1
Not Shown	217852	Fan Blade for 216454 Condensing Units	1
Not Shown	216820	Valve, Auto Expansion, 3 Circuit Distribution	1
Not Shown	SUB-TRI-AXV-KIT	Kit, Cap Tube to AXV, Conversion	1

Table: PL-3 Tri-Channel Compressor Assembly



**TRI-CHANNEL – COMPRESSOR ASSEMBLY (CONTINUED)****CONDENSING UNITS USED FROM 6/2003 THROUGH 9/20/2006**

18	216458	Cond Unit, TriRail 5&6 50Hz <i>(Replaced by KIT-COND-TRI889)</i>	1
19	217868	Fan Motor for 216458 Condensing Units	1
20	217840	Compressor for 216458 Condensing Units	1
Not Shown	217865	Protector for 216458 Condensing Units	1
Not Shown	217866	Relay for 216458 Condensing Units	1
Not Shown	217847	Start Cap for 216458 Condensing Units	1
Not Shown	217819	Fan Blade for 216458 Condensing Units	1
Not Shown	216820	Valve, Auto Expansion, 3 Circuit Distribution	1
Not Shown	SUB-TRI-AXV-KIT	Kit, Cap Tube to AXV, Conversion	1

**CONDENSING UNITS USED FROM 9/13/2006 TO 5/2019 *(Replaced by 516820)***

18	216879	Condensing Unit, Assembly, 48 & 60 Inch, 60Hz	1
19	217808	Fan Motor for 216879 Condensing Units	1
20	527844	Compressor for 216879 Condensing Units	1
Not shown	217813	Protector for 216879 Condensing Units	1
Not Shown	217883	Relay for 216401 Or 216879 Condensing Units	1
Not Shown	217843	Start Cap for 216879 Condensing Units	1
Not Shown	217809	Fan Blade for 216879 Condensing Units	1
Not Shown	216864	TXV Expansion Valve for Serial No. 09072127 and later	1
Not Shown	216859	Insulation, TXV Wrap (Serial No. 02150305 and later)	1
Not Shown	216414	Refrigerant Drier for Serial No. 09072127 and later.	1
Not Shown	216820	Valve, Auto Expansion, 3 Circuit Distribution	1
Not Shown	SUB-TRI-AXV-KIT	Kit, Cap Tube to AXV, Conversion	1

**CONDENSING UNITS USED FROM 9/7/2006 TO PRESENT**

18	216881	Condensing Unit, Assembly, 48 & 60 Inch, 50Hz	1
19	217846	Fan Motor for 216881 Condensing Units	1
20	217845	Compressor for 216881 Condensing Units	1
Not Shown	217849	Protector for 216881 Condensing Units	1
Not Shown	217848	Relay for 216881 Condensing Units	1
Not Shown	217869	Start Cap for 216881 Condensing Unit	1
Not Shown	217809	Fan Blade for 216881 Condensing Units	1
Not Shown	216864	TXV Expansion Valve for Serial No. 09072127 and later	1
Not Shown	216859	Insulation, TXV Wrap (Serial No. 02150305 and later)	1
Not Shown	216414	Refrigerant Drier for Serial No. 09072127 and later.	1
Not Shown	216820	Valve, Auto Expansion, 3 Circuit Distribution	1
Not Shown	SUB-TRI-AXV-KIT	Kit, Cap Tube to AXV, Conversion	1

**CONDENSING UNITS USED FROM 9/13/2006 TO 5/2019 *(Replaced by 516823)***

18	216882	Condensing Unit, Assembly, 74 & 86 Inch, 60Hz	1
19	217851	Fan Motor for 216882 Condensing Units	1
20	217850	Compressor for 216882 Condensing Units	1
Not shown	217855	Protector for 216882 Condensing Units	1
Not Shown	217885	Relay for 216402 Or 216882 Condensing Units	1
Not Shown	217853	Start Cap for 216882 Condensing Units	1
Not Shown	217852	Fan Blade for 216882 Condensing Units	1
Not Shown	216864	TXV Expansion Valve for Serial No. 09072127 and later	1
Not Shown	216859	Insulation, TXV Wrap (Serial No. 02150305 and later)	1
Not Shown	216414	Refrigerant Drier for Serial No. 0972127 and later.	1

Table: PL-3 Tri-Channel Compressor Assembly (Continued)

**TRI-CHANNEL – COMPRESSOR ASSEMBLY (CONTINUED)**

Not Shown	216820	Valve, Auto Expansion, 3 Circuit Distribution	1
Not Shown	SUB-TRI-AXV-KIT	Kit, Cap Tube to AXV, Conversion	1

**CONDENSING UNITS USED FROM 9/21/2006 TO 9/20/2007**

18	216883	Condensing Unit, Assembly, 74 & 86 Inch AXV, 50Hz	1
19	217857	Fan Motor for 216883 Condensing Units	1
20	217880	Compressor for 216883 Condensing Units	1
Not Shown	217861	Protector for 216883 Condensing Units	1
Not Shown	217860	Relay for 216883 Condensing Units	1
Not Shown	217827	Start Cap for 216883 Condensing Units	1
Not Shown	217858	Fan Blade for 216883 Condensing Units	1
Not Shown	216820	Valve, Auto Expansion, 3 Circuit Distribution	1
Not Shown	SUB-TRI-AXV-KIT	Kit, Cap Tube to AXV, Conversion	1

**CONDENSING UNITS USED FROM 9/21/2007 TO PRESENT**

18	216821	Condensing Unit, Assembly, 74 & 86 Inch TXV, .4HP 220VAC 50Hz	1
19	217868	Fan Motor for 216821 Condensing Units	1
20	217840	Compressor for 216821 Condensing Units	1
Not Shown	217865	Protector for 216821 Condensing Units	1
Not Shown	217866	Relay for 216821 Condensing Units	1
Not Shown	217847	Start Cap for 216821 Condensing Units	1
Not Shown	217819	Fan Blade for 216821 Condensing Units	1
Not Shown	216864	TXV Expansion Valve for Serial No. 09072127 and later	1
Not Shown	216859	Insulation, TXV Wrap (Serial No. 02150305 and later)	1
Not Shown	216414	Refrigerant Drier for Serial No. 09072127 and later	1

**CONDENSING UNITS USED FROM 8/21/2012 TO PRESENT**

18	226885	Condensing Unit, 220V 60Hz, 74/86 Tri-Channel	1
19	217868	Fan Motor, for 226885 Condensing Unit	1
20	227935	Compressor, for 226885 Condensing Unit	1
Not Shown	227934	Overload Protector, for 226885 Condensing Unit	1
Not Shown	217866	Relay, for 226885 Condensing Unit	1
Not Shown	217847	Start Capacitor, for 226885 Condensing Unit	1
Not Shown	217819	Fan Blade, for 226885 Condensing Unit	1
18	226490	Condensing Unit 220V 60Hz, 48/60 Tri-Channel	1
19	227913	Fan Motor, for 226490 Condensing Unit	1
20	227930	Compressor, for 226490 Condensing Unit	1
Not Shown	227929	Protector, for 226490 Condensing Unit	1
Not Shown	217881	Relay, for 226490 Condensing Unit	1
Not Shown	227927	Start Capacitor, for 226490 Condensing Unit	1
Not Shown	217809	Fan Blade, for 226490 Condensing Unit	1

**CONDENSING UNITS USED FROM 5/2019 TO PRESENT**

18	516820	Condensing Unit Assembly, 120V 60Hz, 48/60 Tri-Channel	1
19	217851	Condenser Fan Motor, for 516820 Condensing Unit	1
20	527844	Compressor, for 516820 Condensing Unit	1
Not Shown	227858	Protector, for 516820 Condensing Unit	1
Not Shown	227856	Relay, for 516820 Condensing Unit	1
Not Shown	227855	Start Capacitor, for 516820 Condensing Unit	1
Not Shown	217819	Condenser Fan Blade, for 516820 Condensing Unit	1
Not Shown	226407	High Pressure Cut-Out Switch	1

Table: PL-3 Tri-Channel Compressor Assembly (Continued)

TRI-CHANNEL – COMPRESSOR ASSEMBLY (CONTINUED)

**CONDENSING UNITS USED FROM 5/2019 TO PRESENT**

18	516823	Condensing Unit Assembly, 120V 60Hz, 74/86 Tri-channel	1
19	217851	Condenser Fan Motor, for 516823 Condensing Unit	1
20	227854	Compressor, for 516823 Condensing Unit	1
Not Shown	227859	Protector, for 516823 Condensing Unit	1
Not Shown	227857	Relay, for 516823 Condensing Unit	1
Not Shown	227861	Start Compacitor, for 516823 Condensing Unit	1
Not Shown	217819	Condensor Fan Blade, for 516823 Condensing Unit	1
Not Shown	226407	High Pressure Cut-Out Switch	1

Table: PL-3 Tri-Channel Compressor Assembly (Continued)

**HOT FOOD PAN**

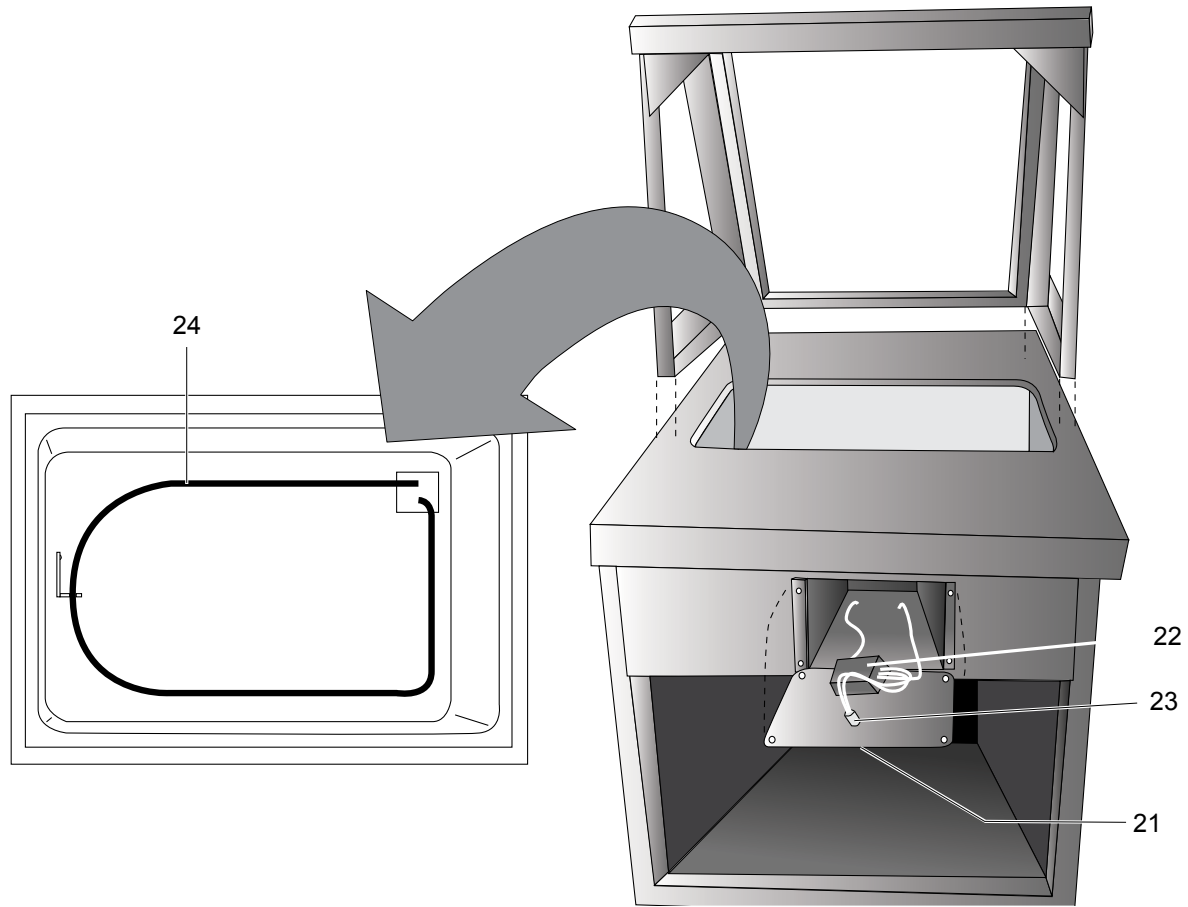

Figure: PL-4 Hot Food Pan

ITEM	QTY.	PART #	DESCRIPTION
21	1	223590	Knob, Electric 120V (Use with 212081 Thermostat)
	1	222082	Knob, Electric 230V (Use with 222081 Thermostat)
22	1	212081	Thermostat, Electric (Current 120V Units & 230V Units Prior to 1/19/2009)
	1	222081	Thermostat, Electric 230V EGO
23	1	215550	Light, Pilot 125V (Amber)
	1	215555	Light, Pilot 230V (Amber) EU
24	1	212942	Dome, Element, 118 VAC, 500 Watt
	1	212943	Dome, Element, 118 VAC, 750 Watt
	1	212945	Dome, Element, 236 VAC, 750 Watt, VDE APPROVED
Not Shown	1	215336	Carving Board, Hot Food DC
Not Shown	1	212935	Element for Sealed Well Unit - 240VAC, 750W
Not Shown	1	222961	Hi Limit Thermostat – Sealed Well Units Only
Not Shown	1	154047	Well, Sealed Well with Drain
Not Shown	1	2935001122	Bain EL Inside Liner Assembly

Table: PL-4 Hot Food Pan

Illustrated Parts List for Tri-Channel Cold Pan SUB-CP-TC

## ALUMINUM DAY COVER – TRI-CHANNEL COLD PAN

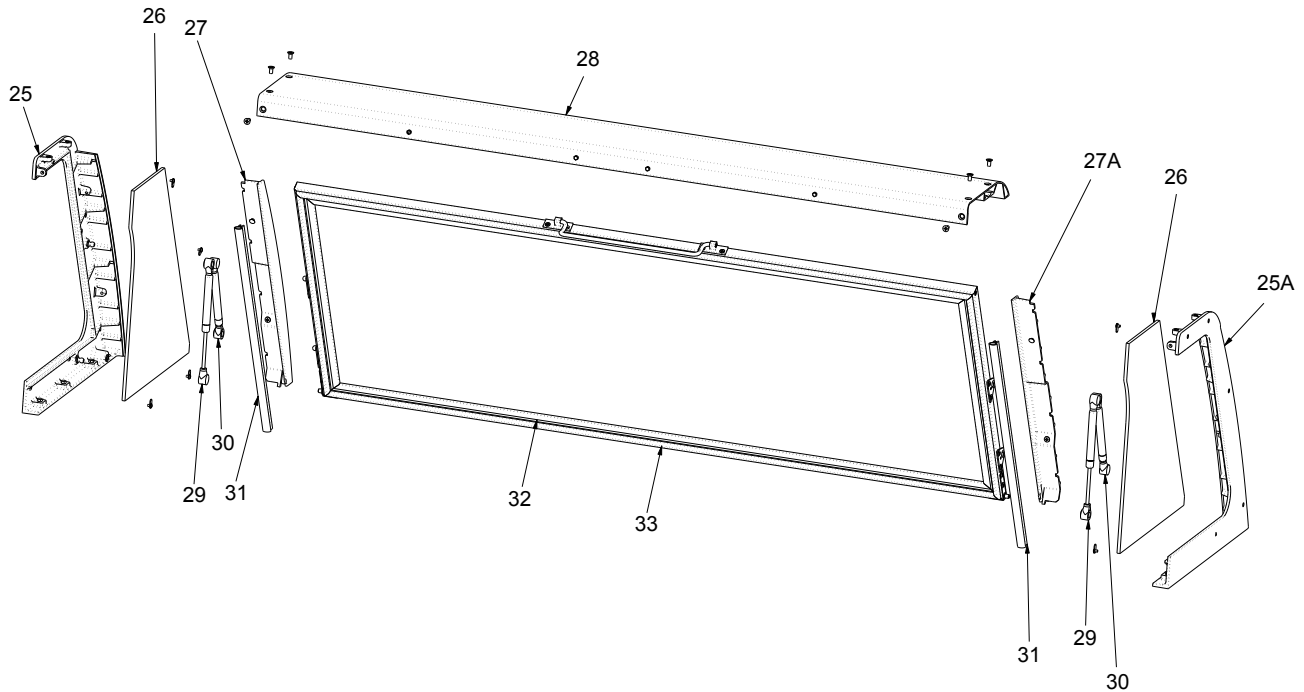

Figure: PL-5 Aluminum Day Cover – Tri-Channel Cold Pan

ITEM	QTY.	PART NUMBER	DESCRIPTION
25	1	REPL-PYLON-LT	Pylon, Aluminum, Left Side w/ Ball Stud & Bronze Bushing
25A	1	REPL-PYLON-RT	Pylon, Aluminum, Right Side w/ Ball Stud & Bronze Bushing
26	2	215763	End Glass SDGC
27	1	215727	Filler, Left SDGC
27A	1	215728	Filler, Right SDGC
28	1	255113	Assy, Shelf Drop 48 SDGC 120V – includes Fixtures, Wiring & Shelf
	1	255114	Assy, Shelf Drop 60 SDGC 120V
	1	255115	Assy, Shelf Drop 74 SDGC 120V
	1	255116	Assy, Shelf Drop 86 SDGC 120V
	1	255125	Assy, Shelf Drop 48 SDGC 220V
	1	255126	Assy, Shelf Drop 60 SDGC 220V
	1	255127	Assy, Shelf Drop 74 SDGC 220V
	1	255128	Assy, Shelf Drop 86 SDGC 220V
Not Shown	1	253725	Bracket, Lock Drop
29	2	214305	Gas Piston Cylinder 40 Lb. – 48" & 60" Day Covers
	2	214332	Gas Piston Cylinder 50 Lb. – 74" & 86" Day Covers
Not Shown	8	214307	End Piece for Cylinder (Lock Cap)
30	2	214306	Gas Dampening Cylinder – All Sizes
Not Shown	1	SHOCK-KIT-48/60	Kit to replace all Shocks/Dampeners/Mounting Hardware for 48" & 60" Day Cover
Not Shown	1	SHOCK-KIT-74/86	Kit to replace all Shocks/Dampeners/Mounting Hardware for 74" & 86" Day Cover
31	2	215765 & 214543	Extrusion, Collapsible Gasket Assembly
32	1	255046KIT	Kit, Assembly, Glass Drop, 48" SDGC
	1	255047KIT	Kit, Assembly, Glass Drop, 60" SDGC
	1	255048KIT	Kit, Assembly, Glass Drop, 74" SDGC
	1	255049KIT	Kit, Assembly, Glass Drop, 86" SDGC

Table: PL-5 Aluminum Day Cover – Tri-Channel Cold Pan

ALUMINUM DAY COVER – TRI-CHANNEL COLD PAN (CONTINUED)

Not Shown	1	215776	Handle, Wire SDGC Front Mount
Not Shown	1	215976	Handle, Wire SDGC Top Mount
Not Shown	1	215775	Mount for Wire Handle SDGC
Not Shown	4	214308	Mounting Bracket, Gas Piston Cylinder
Not Shown	8	215769	Screw, 10-24 x 1/4" FPFM SS
Not Shown	2	215138	Hinge Pin, Norfab Glass Drops
Not Shown	1	255618	Spacer, Gasket Relief (74" & 86" Glass Drop Assemblies)
Not Shown	2	213028	Screw, 10-24 x 3/8" PTHMS SS (74" & 86" Glass Drops)
Not Shown	1	217260	Aluminum Touch Up Paint (Spray)
Not Shown	1	217261	Aluminum Touch Up Paint (Bottle)
33	1	216726	Gasket for 48" Day Cover
	1	216727	Gasket for 60" Day Cover
	1	216728	Gasket for 74" Day Cover
	1	216729	Gasket for 86" Day Cover
Not Shown	A/R	225800	Light Fixture-12, T5 Fluorescent-HERA, 8W-120V (After 2/2009)
Not Shown	A/R	225804	Light Fixture-12, T5 Fluorescent-HERA, 8W-230V (After 2/2009)
Not Shown	A/R	225801	Light Fixture-24, T5 Fluorescent-HERA, 14W-120V (After 2/2009)
Not Shown	A/R	225805	Light Fixture-24, T5 Fluorescent-HERA, 14W-230V (After 2/2009)
Not Shown	A/R	215820	Light Fixture-20.6, T4 Fluorescent-LITECO, 16W-120V (Until 2/2009)
Not Shown	A/R	215853	Light Fixture-20.6, T4 Fluorescent-LITECO, 16W-220V (Until 2/2009)
Not Shown	A/R	225802	Light Fixture-36, T5 Fluorescent-HERA, 21W-120V (After 2/2009)
Not Shown	A/R	225806	Light Fixture-36, T5 Fluorescent-HERA, 21W-230V (After 2/2009)
Not Shown	A/R	225803	Light Fixture-48, T5 Fluorescent-HERA, 28W-120V (After 2/2009)
Not Shown	A/R	225807	Light Fixture-48, T5 Fluorescent-HERA, 28W-220V (After 2/2009)
Not Shown	A/R	225808	Bulb, T5 Fluorescent-HERA, 8W-120/230V (After 2/2009)
Not Shown	A/R	225809	Bulb, T5 Fluorescent-HERA, 14W-120/230V (After 2/2009)
Not Shown	A/R	215883	Bulb, T4 Fluorescent-LITECO, 16W-120V (Until 2/2009)
Not Shown	A/R	215855	Bulb, T4 Fluorescent-LITECO, 16W-220V (Until 2/2009)
Not Shown	A/R	225810	Bulb, T5 Fluorescent-HERA, 21W-120/230V (After 2/2009)
Not Shown	A/R	225811	Bulb, T5 Fluorescent-HERA, 28W-120/230V (After 2/2009)
Not Shown	A/R	225950	Light Fixture-12, LED-SSL, FEELUX, 120V (After 8/2011)
Not Shown	A/R	225951	Light Fixture-24, LED-SSL, FEELUX, 120V (After 8/2011)
Not Shown	A/R	225770	Light Fixture-36, LED-SSL, FEELUX, 120V (After 8/2011)
Not Shown	A/R	225952	Light Fixture-48, LED-SSL, FEELUX, 120V (After 8/2011)
Not Shown	A/R	225960	Light Fixture-12, LED-SSL, FEELUX, 230V (After 8/2011)
Not Shown	A/R	225961	Light Fixture-24, LED-SSL, FEELUX, 230V (After 8/2011)
Not Shown	A/R	225972	Light Fixture-36, LED-SSL, FEELUX, 230V (After 8/2011)
Not Shown	A/R	225962	Light Fixture-48, LED-SSL, FEELUX, 230V (After 8/2011)
Not Shown	1	225963	Cord, Power SSL, FEELUX 120V, 6' Long (After 8/2011)
Not Shown	1	225964	Cord, Power SSL, FEELUX, 230V, 6' Long (After 8/2011)
Not Shown	A/R	225965	Connector, Power SSL, FEELUX, 120V (After 8/2011)
Not Shown	A/R	225966	Connector, Power SSL, FEELUX, 230V (After 8/2011)
Not Shown	A/R	225768	Light Fixture-12, LED-SSL, HERA, 120V (After 4/2016)
Not Shown	A/R	225769	Light Fixture-24, LED-SSL, HERA, 120V (After 4/2016)
Not Shown	A/R	225770	Light Fixture-36, LED-SSL, HERA, 120V (After 4/2016)
Not Shown	A/R	225771	Light Fixture-48, LED-SSL, HERA, 120V (After 4/2016)
Not Shown	A/R	225773	Light Fixture-12, LED-SSL, HERA, 230V (After 4/2016)
Not Shown	A/R	225774	Light Fixture-24, LED-SSL, HERA, 230V (After 4/2016)
Not Shown	A/R	225775	Light Fixture-36, LED-SSL, HERA, 230V (After 4/2016)
Not Shown	A/R	225776	Light Fixture-48, LED-SSL, HERA, 230V (After 4/2016)
Not Shown	1	225772	Cord, Power SSL-HERA, 120V (After 4/2016)
Not Shown	1	225777	Cord, Power SSL-HERA, 230V (After 4/2016)
Not Shown	A/R	225778	Jumper, Power SSL-HERA, 120/230V (After 4/2016)

Table: PL-5 Aluminum Day Cover – Tri-Channel Cold Pan (Continued)

ALUMINUM DAY COVER – HOT FOOD PAN

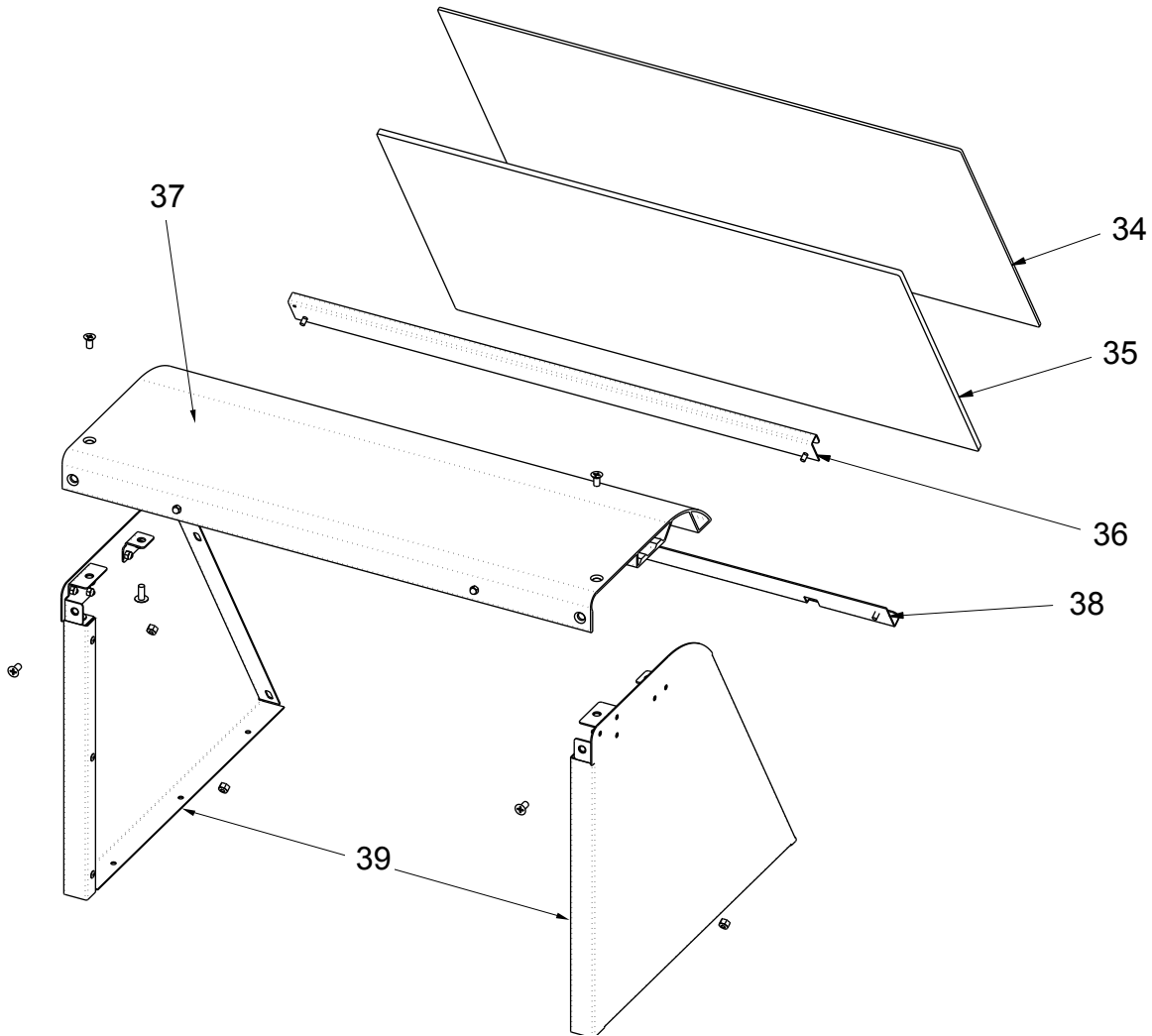

Figure: PL-6 Aluminum Day Cover – Hot Food Pan

ITEM	QTY.	PART NUMBER	DESCRIPTION
34	1	255401	PLEXI 1/4" 16.5" HFC-CLEAR
	1	255402	PLEXI 1/4" 18" HFC-CLEAR
	1	255403	PLEXI 1/4" 19" HFC-CLEAR
	1	255404	PLEXI 1/4" 24" HFC-CLEAR
	1	255405	PLEXI 1/4" 25" HFC-CLEAR
	1	255406	PLEXI 1/4" 36" HFC-CLEAR
	1	255407	PLEXI 1/4" 37" HFC-CLEAR
	1	255408	PLEXI 1/4" 48" HFC-CLEAR
	1	255409	PLEXI 1/4" 49" HFC-CLEAR
	1	255410	PLEXI 1/4" 60" HFC-CLEAR
	1	255411	PLEXI 1/4" 61" HFC-CLEAR

– The 1/4" pieces should be in front per Subway. Changed 11/06.

If ordering new replacement parts: both clear and frosted pieces must be ordered if the order shipped prior to 11/06.

Table: PL-6 Aluminum Day Cover – Hot Food Pan

ALUMINUM DAY COVER – HOT FOOD PAN

ITEM	QTY.	PART NUMBER	DESCRIPTION
35	1	255412	PLEXI 1/8" 16.5" HFC-FROSTED
	1	255413	PLEXI 1/8" 18" HFC-FROSTED
	1	255414	PLEXI 1/8" 19" HFC-FROSTED
	1	255415	PLEXI 1/8" 24" HFC-FROSTED
	1	255416	PLEXI 1/8" 25" HFC-FROSTED
	1	255417	PLEXI 1/8" 36" HFC-FROSTED
	1	255418	PLEXI 1/8" 37" HFC-FROSTED
	1	255419	PLEXI 1/8" 48" HFC-FROSTED
	1	255420	PLEXI 1/8" 49" HFC-FROSTED
	1	255421	PLEXI 1/8" 60" HFC-FROSTED
	1	255422	PLEXI 1/8" 61" HFC-FROSTED
	36	1	255182
1		255183	Rail, Top 18" HFC
1		255184	Rail, Top 19" HFC
1		255185	Rail, Top 24" HFC
1		255186	Rail, Top 25" HFC
1		255187	Rail, Top 36" HFC
1		255188	Rail, Top 37" HFC
1		255189	Rail, Top 48" HFC
1		255190	Rail, Top 49" HFC
1		255191	Rail, Top 60" HFC
1		255192	Rail, Top 61" HFC
37		1	255129
	1	255130	Assembly, Shelf 18" HFC 120V
	1	255301	Assembly, Shelf 18" HFC 220V
	1	255131	Assembly, Shelf 19" HFC 120V
	1	255302	Assembly, Shelf 19" HFC 220V
	1	255132	Assembly, Shelf 24" HFC 120V
	1	255140	Assembly, Shelf 24" HFC 220V
	1	255133	Assembly, Shelf 25" HFC 120V
	1	255141	Assembly, Shelf 25" HFC 220V
	1	255134	Assembly, Shelf 36" HFC 120V
	1	255142	Assembly, Shelf 36" HFC 220V
	1	255135	Assembly, Shelf 37" HFC 120V
	1	255143	Assembly, Shelf 37" HFC 220V
	1	255136	Assembly, Shelf 48" HFC 120V
	1	255144	Assembly, Shelf 48" HFC 220V
1	255137	Assembly, Shelf 49" HFC 120V	
1	255145	Assembly, Shelf 49" HFC 220V	

– The 1/8" pieces should be in rear per Subway. Changed 11/06.

If ordering new replacement parts: both clear and frosted pieces must be ordered if the order shipped prior to 11/06.

All others include lights/wires

Table: PL-6 Aluminum Day Cover – Hot Food Pan (Continued)



## ALUMINUM DAY COVER – HOT FOOD PAN (CONTINUED)

ITEM	QTY.	PART NUMBER	DESCRIPTION
37 (cont.)	1	255138	Assembly, Shelf 60" HFC 120V
	1	255139	Assembly, Shelf 61" HFC 120V
	1	255147	Assembly, Shelf 61" HFC 220V
38	1	255171	Rail, Bottom 16.5" HFC
	1	255172	Rail, Bottom 18" HFC
	1	255173	Rail, Bottom 19" HFC
	1	255174	Rail, Bottom 24" HFC
	1	255175	Rail, Bottom 25" HFC
	1	255176	Rail, Bottom 36" HFC
	1	255177	Rail, Bottom 37" HFC
	1	255178	Rail, Bottom 48" HFC
	1	255179	Rail, Bottom 49" HFC
	1	255180	Rail, Bottom 60" HFC
	1	255181	Rail, Bottom 61" HFC
39	1	255148	Assembly, Pylon, Left
	1	255149	Assembly, Pylon, Right
Not Shown	A/R	225800	Light Fixture-12", T5 Fluorescent-HERA, 8W-120V (AFTER 2/2009)
	A/R	225804	Light Fixture-12", T5 Fluorescent-HERA, 8W-220V (AFTER 2/2009)
	A/R	215864	Light Fixture-15.51", T4 Fluorescent-LITECO, 8w-120V (UNTIL 2/2009)
	A/R	215865	Light Fixture-15.51", T4 Fluorescent-LITECO, 8W-220V (UNTIL 2/2009)
	A/R	215850	Light Fixture-16.5", T4 Fluorescent-LITECO, 12W-120V (UNTIL 2/2009)
	A/R	215852	Light Fixture-16.5", T4 Fluorescent-LITECO, 12W-220V (UNTIL 2/2009)
	A/R	225801	Light Fixture-24", T5 Fluorescent-HERA, 14W-120V (AFTER 2/2009)
	A/R	225805	Light Fixture-24", T5 Fluorescent-HERA, 14W-220V (AFTER 2/2009)
	A/R	225803	Light Fixture-48", T5 Fluorescent-HERA, 28W-120V (AFTER 2/2009)
	A/R	225807	Light Fixture-48", T5 Fluorescent-HERA, 28W-220V (AFTER 2/2009)
Not Shown	A/R	225950	Light Fixture-12", LED-SSL, 120V (AFTER 10/2011)
	A/R	225960	Light Fixture-12", LED-SSL, 230V (AFTER 10/2011)
	A/R	225952	Light Fixture-48", LED-SSL, 120V (AFTER 10/2011)
	A/R	225962	Light Fixture-48", LED-SSL, 230V (AFTER 10/2011)
Not Shown	A/R	225808	Bulb, T5 Fluorescent-HERA, 8W-120/220V (AFTER 2/2009)
	A/R	215885	Bulb, T4 Fluorescent-LITECO, 8W-120V (UNTIL 2/2009)
	A/R	215866	Bulb, T4 Fluorescent-LITECO, 8W-220V (UNTIL 2/2009)
	A/R	215884	Bulb, T4 Fluorescent-LITECO, 12W-120V (UNTIL 2/2009)
	A/R	215854	Bulb, T4 Fluorescent-LITECO, 12W-220V (UNTIL 2/2009)
	A/R	225809	Bulb, T5 Fluorescent-HERA, 14W-120/220V (AFTER 2/2009)
	A/R	225811	Bulb, T5 Fluorescent-HERA, 28W-120/220V (AFTER 2/2009)

Table: PL-6 Aluminum Day Cover – Hot Food Pan (Continued)

STAINLESS STEEL DAY COVER – TRI-CHANNEL COLD PAN & HOT PAN UNITS

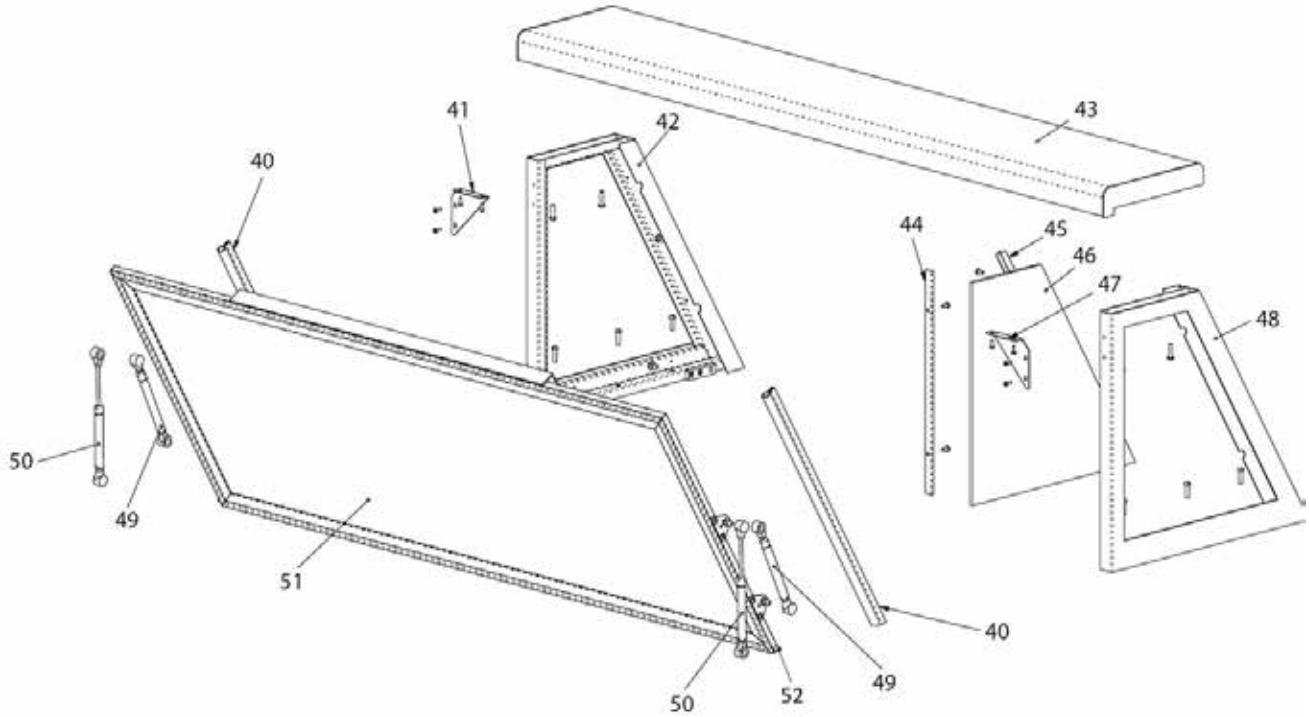

Figure: PL-7 Stainless Steel Day Cover – Tri-Channel Cold Pan and Hot Pan Units

ITEM	QTY.	PART NUMBER	DESCRIPTION
40	2	214932	Extrusion, Collapsible Gasket
Not Shown	A/R	214543	Vinyl Foam Cord 1/2" Black W/Tpr 70 Duro
41	1	252929	Bracket, Reinforcement , Anti Sway, Lt
42	1	253679	Assembly, Pylon Lt Drop SDG
	1	254046	Assembly, Pylon Lt Fixed 3" SDG
	1	253681	Assembly, Pylon Lt Fixed SDG
Not Shown	2	214309	Ball Mount
Not Shown	8	155358	Nut, Nylon Insert 6-32
43	1	253651	Assembly, Shelf, Top 37" SDG
	1	253669	Assembly, Reflect, Fixed 37" 120V, SDG
	1	253697	Assembly, Reflect, Fixed 37" 220V, SDG
	1	253654	Assembly, Shelf, Top 48" SDG
	1	253672	Assembly, Reflect, Drop 48" 120V, SDG
	1	253702	Assembly, Reflect, Drop 48" 220V, SDG
	1	253652	Assembly, Shelf, Top 49" SDG
	1	253670	Assembly, Reflect, Fixed 49" 120V, SDG
	1	253699	Assembly, Reflect, Fixed 49" 220V, SDG
	1	253655	Assembly, Shelf, Top 60" SDG
	1	253673	Assembly, Reflect, Drop 60" 120V, SDG
	1	253703	Assembly, Reflect, Drop 60" 220V, SDG

Table: PL-7 Stainless Steel Day Cover – Tri-Channel Cold Pan and Hot Pan Units

**STAINLESS STEEL DAY COVER –  
TRI-CHANNEL COLD PAN AND HOT PAN UNITS (CONTINUED)**

43	1	253653	Assembly, Shelf, Top 61" SDG
(Continued)	1	253671	Assembly, Reflect, Fixed 61" 120V, SDG
	1	253701	Assembly, Reflect, Fixed 61" 220V, SDG
	1	253656	Assembly, Shelf, Top 74" SDG
	1	253674	Assembly, Reflect, Drop 74" 120V, SDG
	1	253704	Assembly, Reflect, Drop 74" 220V, SDG
	1	253657	Assembly, Shelf, Top 86" SDG
	1	253675	Assembly, Reflect, Drop 86" 120V, SDG
	1	253705	Assembly, Reflect, Drop 86" 220V, SDG
44	1	253625	Channel, Glass SDG SS Bottom
45	1	253624	Channel, GlassSDG SS Top
46	1	214183	Glass End Pylon
47	1	252930	Bracket, Reinforcement, Anti Sway Rt
48	1	253680	Assembly, Pylon Rt Drop SDG
	1	254047	Assembly, Pylon Rt Fixed 3" SDG
	1	253682	Assembly, Pylon Rt Fixed SDG
49	2	214306	Cylinder - Gas 3.0" Dampening
50	2	214305	Cylinder - Gas 3.15" 40lbs (48" & 60" Units)
	2	214332	Cylinder - Gas 3.15" 50lbs (74" & 86" Units)
51	1	252985KIT	Kit, Glass Drop, Nor-Fab 48" Assembly
	1	252986KIT	Kit, Glass Drop, Nor-Fab 60" Assembly
	1	252987KIT	Kit, Glass Drop, Nor-Fab 74" Assembly
	1	252988KIT	Kit, Glass Drop, Nor-Fab 86" Assembly
Not Shown	2	215138	Hinge Pin, Glass Drop Assemblies
Not Shown	8	213028	Screw, 10-24 x 3/8" PTHMS SS
Not Shown	1	SUB-DC-CRNR-KIT	Kit, Glass Drop Corner Reinforcement
Not Shown	1	255618	Spacer, Gasket Relief (74" & 86" Drop Glass Assemblies)
Not Shown	1	214361	Glass Cover-Sub Fixed 37, 34" x 23", No Handle/Gasket
Not Shown	1	214181	Glass Cover-Sub Fixed 48, 45" x 23", No Handle/Gasket
Not Shown	1	214362	Glass Cover-Sub Fixed 49, 46" x 23", No Handle/Gasket
Not Shown	1	214182	Glass Cover-Sub Fixed 60, 57" x 23", No Handle/Gasket
Not Shown	1	214363	Glass Cover-Sub Fixed 61, 58" x 23", No Handle/Gasket
52	4	214308	Mounting Bracket, Gas Piston Cylinder
Not Shown	8	214307	End Piece for Cylinders (Lock Caps)
Not Shown	1	253725	Bracket, Lock Drop

Table: PL-7 Stainless Steel Day Cover – Tri-Channel Cold Pan and Hot Pan Units (Continued)

**STAINLESS STEEL DAY COVER –  
TRI-CHANNEL COLD PAN AND HOT PAN UNITS (CONTINUED)**

**HERA T4 LIGHT FIXTURES, REPLACEMENT BULBS, CORDS & CONNECTORS**

Not Shown	A/R	SUB-HERAFIXT120	Light Fixture-19", T4 Fluorescent-HERA, 18W-120V (UNTIL 9/2006)
Not Shown	A/R	0652010	Light Fixture-19", T4 Fluorescent-HERA, 18W-220V (UNTIL 9/2006)
Not Shown	1	212202	Hera Cord with Plug, 120VAC
Not Shown	1	214303	Hera Cord with EU Plug, 220VAC
Not Shown	1	225812	Hera Cord with Plug, 120VAC (NEW)
Not Shown	A/R	214519	T4 Clip, Light Fixture Mounting (old)
Not Shown	A/R	0651428	Bulb, T4 Fluorescent-HERA, 18W-120/220V (UNTIL 9/2006)
Not Shown	A/R	214432	Hera, Connector, Direct Light Fixture, 120VAC
Not Shown	A/R	212305	Hera, Connector, Pin to Pin, 220V (New)
Not Shown	A/R	216117	Hera T4 Lens Cover for 18W Bulb

**HERA T5 LIGHT FIXTURES** *(Use only when upgrading all T4 fixtures to T5 lighting)*

ITEM	QTY.	PART NUMBER	DESCRIPTION
Not Shown	A/R	SUB-T5LTS-A120	Hera T5 Light Kit, 15-29.5 Inch, 120VAC for 25 Inch Day Covers
Not Shown	A/R	SUB-T5LTS-A220	Hera T5 Light Kit, 15-29.5 Inch, 230VAC for 25 Inch Day Covers
Not Shown	A/R	SUB-T5LTS-B120	Hera T5 Light Kit, 30-47 Inch, 120VAC for 25 Inch Day Covers
Not Shown	AR	SUB-T5LTS-B220	Hera T5 Light Kit, 30-47 Inch, 230VAC for 25 Inch Day Covers
Not Shown	A/R	SUB-T5LTS-C120	Hera T5 Light Kit, 47.5-51 Inch, 120VAC for 48 Inch Day Covers
Not Shown	A/R	SUB-T5LTS-C220	Hera T5 Light Kit, 47.5-51 Inch, 230VAC for 48 Inch Day Covers
Not Shown	A/R	SUB-T5LTS-D120	Hera T5 Light Kit, 51.5-83.5 Inch, 120VAC for 60 Inch Day Covers
Not Shown	A/R	SUB-T5LTS-D220	Hera T5 Light Kit, 51.5-83.5 Inch, 230VAC for 60 Inch Day Covers
Not Shown	A/R	SUB-T5LTS-E120	Hera T5 Light Kit, 64-75.5 Inch, 120VAC for 74 Inch Day Covers
Not Shown	A/R	SUB-T5LTS-E220	Hera T5 Light Kit, 64-75.5 Inch, 230VAC for 74 Inch Day Covers
Not Shown	A/R	SUB-T5LTS-F120	Hera T5 Light Kit, 76+ Inch, 120VAC for 86 Inch Day Covers
Not Shown	A/R	SUB-T5LTS-F220	Hera T5 Light Kit, 76+ Inch, 230VAC for 86 Inch Day Covers
Not Shown	A/R	SUB-T5LTS-G120	Hera T5 Light Kit, 120VAC For Purse Rails
Not Shown	A/R	SUB-T5LTS-G220	Hera T5 Light Kit, 230VAC For Purse Rails

Table: PL-7 Stainless Steel Day Cover – Tri-Channel Cold Pan and Hot Pan Units (Continued)





Your Solutions Partner

## **Duke Manufacturing Co.**

**2305 N. Broadway • St. Louis, MO 63102**

**800-735-3853 • 314-231-1130**

**Fax: 314-231-5074**

**[www.dukemfg.com](http://www.dukemfg.com)**