



Your Solutions Partner

# Specifications

F.O.B. Sedalia, Missouri 65301



Model 259074 Shown Above

Approval Stamp(s):

PRODUCT INFORMATION:

PROJECT: \_\_\_\_\_

ITEM: \_\_\_\_\_

QUANTITY: \_\_\_\_\_

MODEL:

Duke Dri-Channel™ Soup Warmer

- 259073                  Single - 1/3 Well
- 259074                  Double 1/3 Wells
- 259075                  Triple 1/3 Wells

Product Features:

- Dry Operation - No water needed.
- Easy cleanability and sanitation - No soiled water to drain.
- Improved employee safety - Reduces burn potential with no transfer of hot water.
- Aluminum "heat sink" transfers even heat to the product.
- Virtually eliminates scorching during product hold times.

CONTROLS

- Each well has it's own temerature control.

Agency Listings:



DUKE MANUFACTURING CO.

2305 N. Broadway

St. Louis, MO 63102

800.735.3853 Toll Free

314.231.5074 Fax

www.dukemfg.com

SS-1225 Dri-Channel Soup Warmer

Specification subject to change



PRODUCT HOLDING UNIT - Soup Warmer

Catalog No. Soup Warmer

A.I.A. File No. 35-C-13

# Dri-Channel™ Soup Warmer

A.I.A. File No. 35-C-13

Catalog No. Soup Warmer

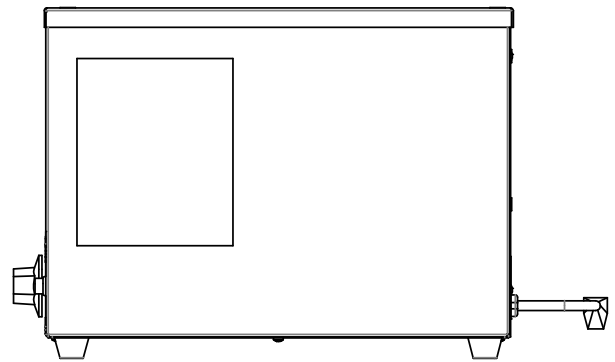
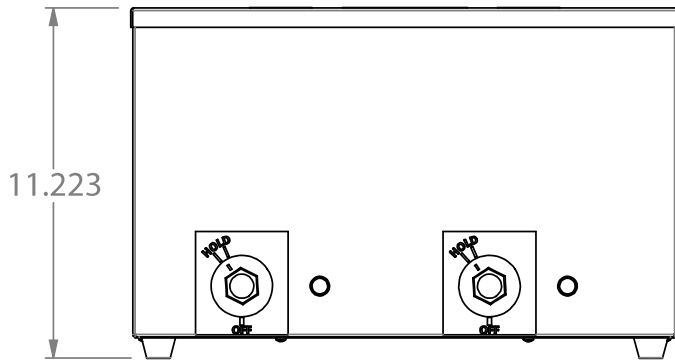
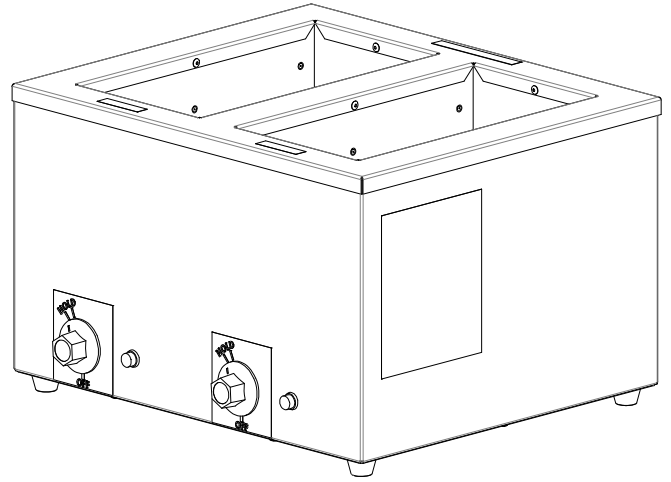
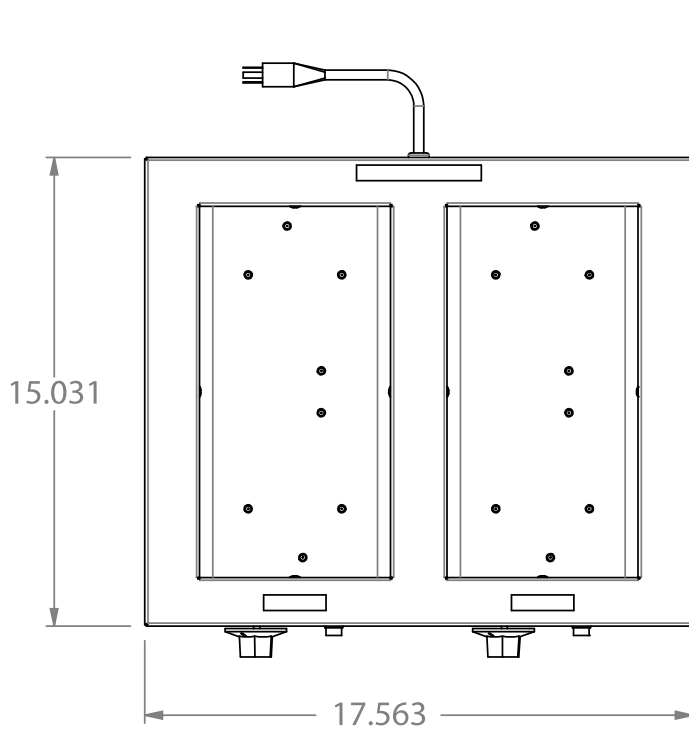

259074 Shown Above

PRODUCT HOLDING UNIT - Soup Warmer

## ELECTRICAL SPECIFICATIONS:

## DIMENSIONS:

Freight Class: 100

Model	120 Volt - HZ 60			Height		Width		Depth		Max. Soup Capacity	Crated Ship Weight	
	Watts	Amps	NEMA	in.	cm	in.	cm	in.	cm		lbs.	kg
259073	500	4.2	P5-15	11.25	28.58	9.5	24.13	15.0	38.1	4 Qt	37.00	16.78
259074	1000	8.4	P5-15	11.25	28.58	17.5	44.45	15.0	38.1	8 Qt	47.00	21.32
259075	1500	12.6	P5-15	11.25	28.58	25.5	64.77	15.0	38.1	12 Qt	67.00	30.39



**Duke Manufacturing Co.**  
2305 N. Broadway  
St. Louis, MO 63102

Phone: 314-231-1130  
Toll Free: 1-800-735-3853  
Fax: 314-231-5074

[www.dukemfg.com](http://www.dukemfg.com)

Printed in U.S.A  
© 2021, Duke Manufacturing Co.